

4

3

2

1

REV	DRWN	CHK'D	DATE	DESCRIPTION
-----	------	-------	------	-------------

B

B

A

A

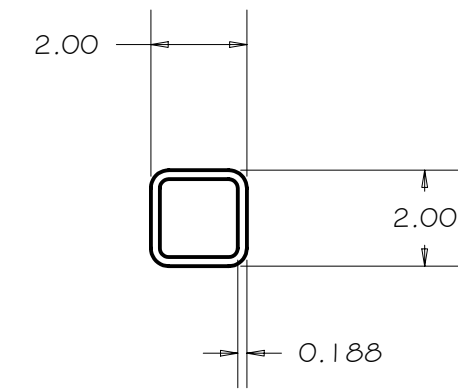
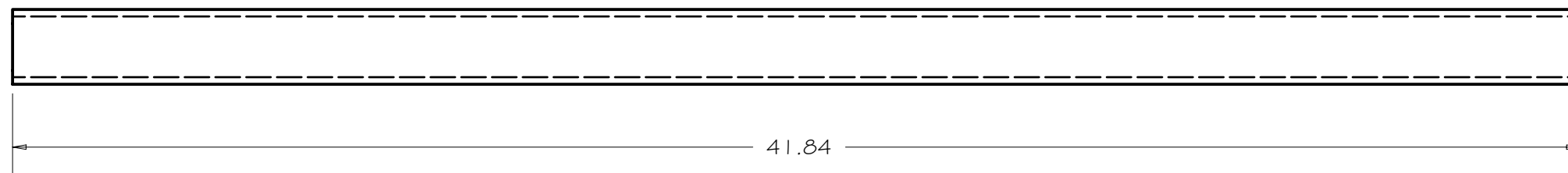

SCALE 1 / 4

TOLERANCES UNLESS OTHERWISE NOTED:  
 FRACTIONAL: 0"-6": ±1/64" 6"-24": ±1/32"  
 24"+: ±1/16"  
 DECIMAL: X.X: ±0.1000" X.XX: ±0.0100"  
 X.XXX: ±0.0050" X.XXXX: ±0.0001"  
 ANGLES: ±0.5° FINISH: 125 MICRO INCHES  
 BREAK ALL SHARP EDGES & CORNERS 1/64" MAX



DRAWN	vernon	1/24/2005	Sol-Gel Facility	
CHECKED				
DESIGNED	vernon		TITLE	
ENGINEER	VRW		ADC SPREADER, BEAM	
MATERIAL	STEEL	FINISH	PROJECT CODE	DWG NO
			SG4116	SG4113
			QTY: 1	REV A

4

3

2

1

A

A