

4

3

2

1

REV	DRWN	CHK'D	DATE	DESCRIPTION
-----	------	-------	------	-------------

B

B

A

A

A

A

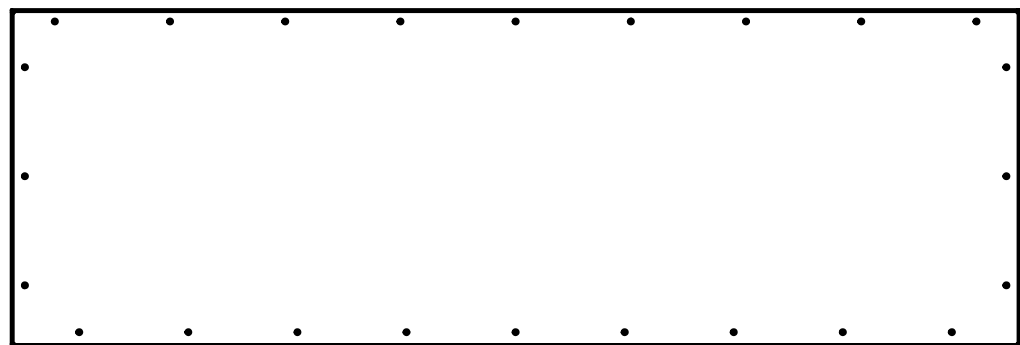

1

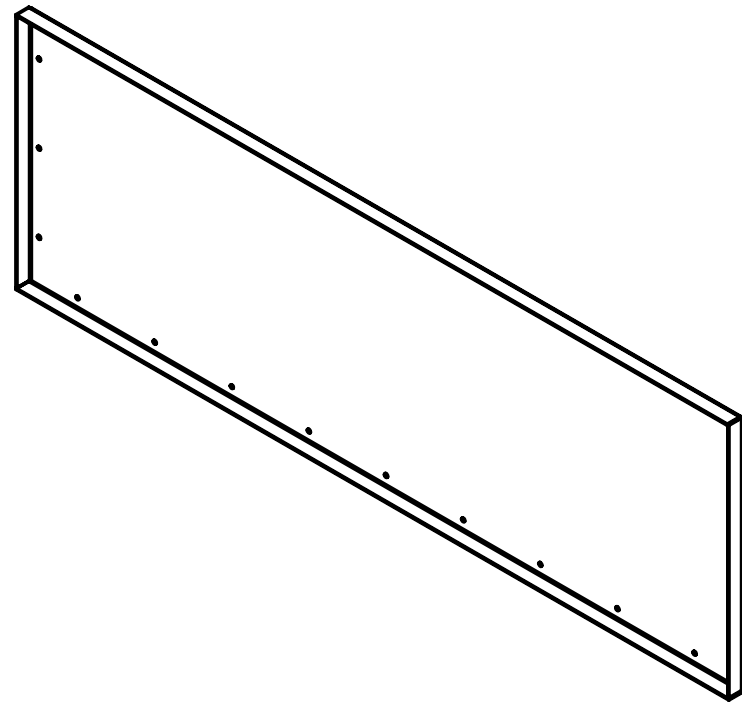

NOTE:

NOT SHOWN, HANDLES, MOUNT HOLES

SCALE 1 / 10

Parts List			
ITEM	QTY	PART NUMBER	DESCRIPTION
1	1	SG3522	HARDENING TANK TOP

TOLERANCES UNLESS OTHERWISE NOTED:  
 FRACTIONAL: 0"-6": ±1/64" 6"-24": ±1/32"  
 24"+: ±1/16"  
 DECIMAL: X.X: ±0.1000" X.XX: ±0.0100"  
 X.XXX: ±0.0050" X.XXXX: ±0.0001"  
 ANGLES: ±0.5° FINISH: 125 MICRO INCHES  
 BREAK ALL SHARP EDGES & CORNERS 1/64" MAX

MATERIAL	FINISH

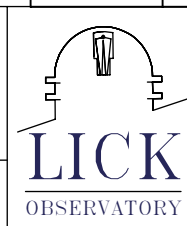

DRAWN	vernon	7/20/2005
CHECKED		
DESIGNED	vernon	
ENGINEER	VRW	

PROJECT CODE		DWG NO	REV
NEXT ASSY		SG3525	A
		SG3523	1/1

4

3

2

1

