

REV	DRWN	CHK'D	DATE	DESCRIPTION

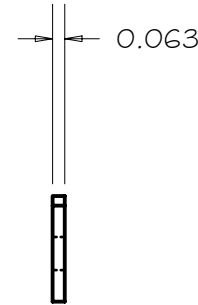

TOLERANCES UNLESS OTHERWISE NOTED:  
 FRACTIONAL: 0"-6": ±1/64" 6"-24": ±1/32"  
 24"+: ±1/16"  
 DECIMAL: X.X: ±0.1000" X.XX: ±0.0100"  
 X.XXX: ±0.0050" X.XXXX: ±0.0001"  
 ANGLES: ±0.5° FINISH: 125 MICRO INCHES  
 BREAK ALL SHARP EDGES & CORNERS 1/64" MAX

MATERIAL	FINISH
ALUMINUM	

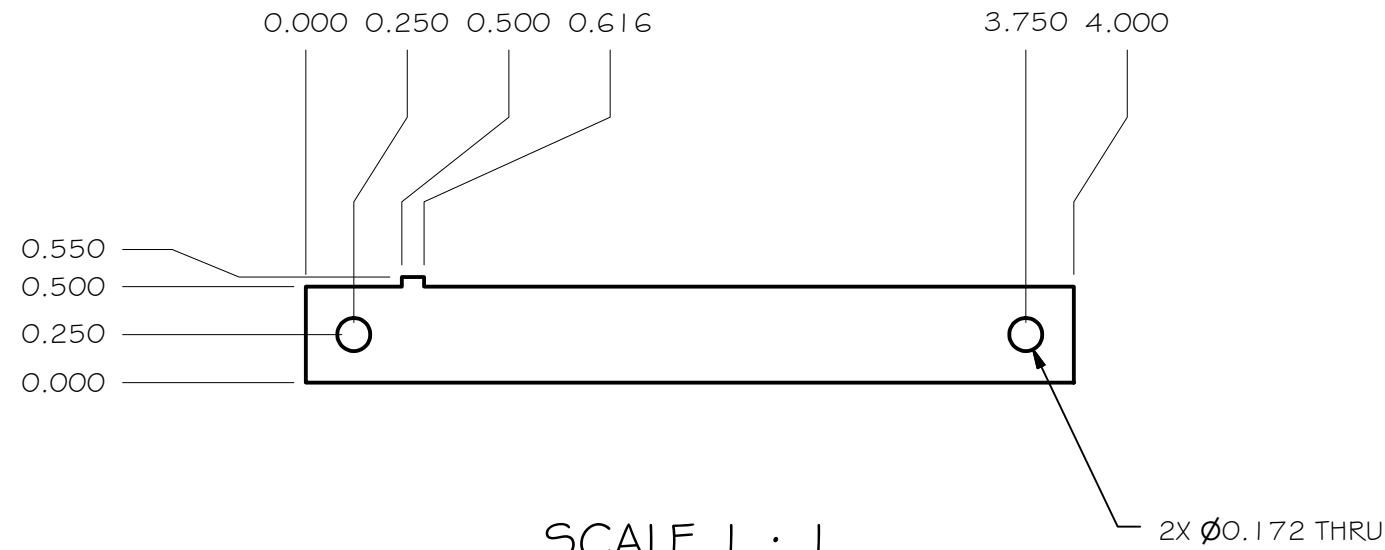
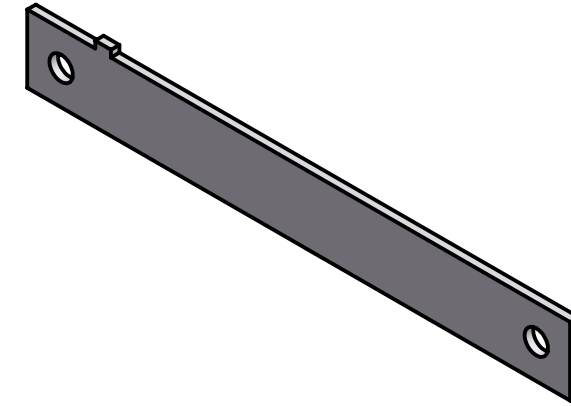

DRAWN	vernon	2/16/2005
CHECKED		
DESIGNED	vernon	
ENGINEER	vernon	

QTY: 2

PROJECT CODE		DWG NO	REV
NEXT ASSY		A8094	A
A8090			1

Cassegrain ADC

GUIDE BAR