

REV	DRWN	CHK'D	DATE	DESCRIPTION
-----	------	-------	------	-------------

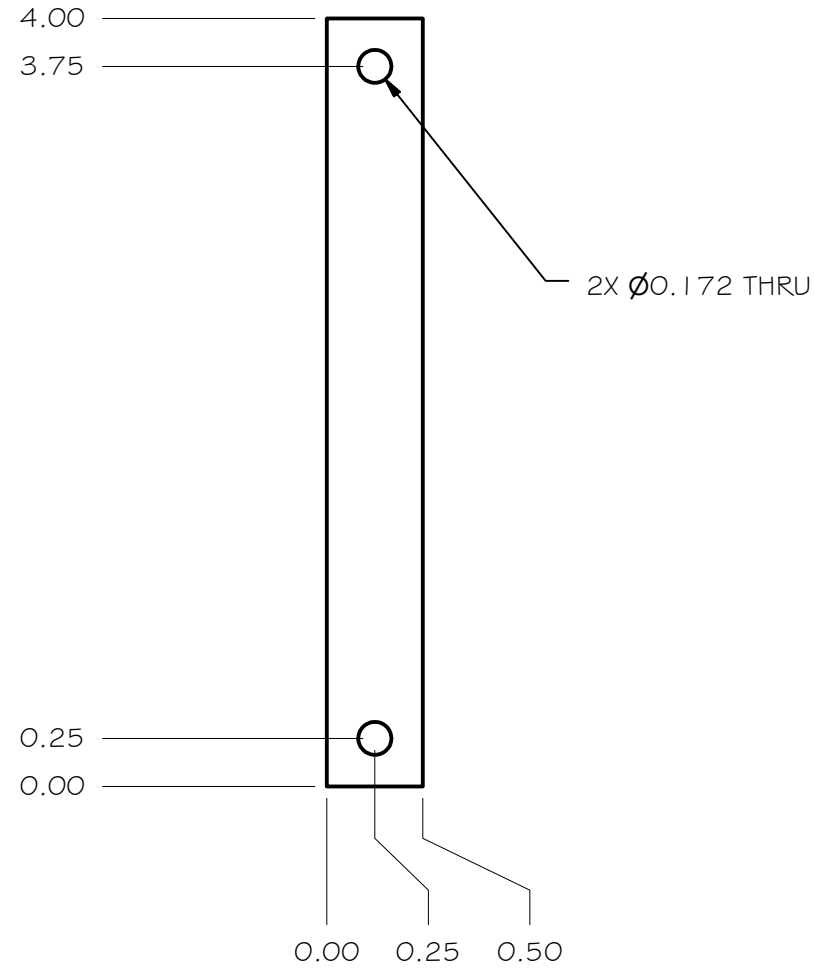

SCALE 1 : 1

TOLERANCES UNLESS OTHERWISE NOTED:
 FRACTIONAL: 0"-6": ±1/64" 6"-24": ±1/32"
 24"+: ±1/16"
 DECIMAL: X.X: ±0.1000" X.XX: ±0.0100"
 X.XXX: ±0.0050" X.XXXX: ±0.0001"
 ANGLES: ±0.5° FINISH: 125 MICRO INCHES
 BREAK ALL SHARP EDGES & CORNERS 1/64" MAX



DRAWN	vernon	2/17/2005
CHECKED		
DESIGNED	vernon	
ENGINEER	vernon	

PROJECT CODE		DWG NO
NEXT ASSY		REV

MATERIAL	FINISH
MYLAR	

QTY: 2

Cassegrain ADC	GUIDE BAR SHIM	A8089	A
A8090			1