

4

3

2

1

REV	DRWN	CHK'D	DATE	DESCRIPTION

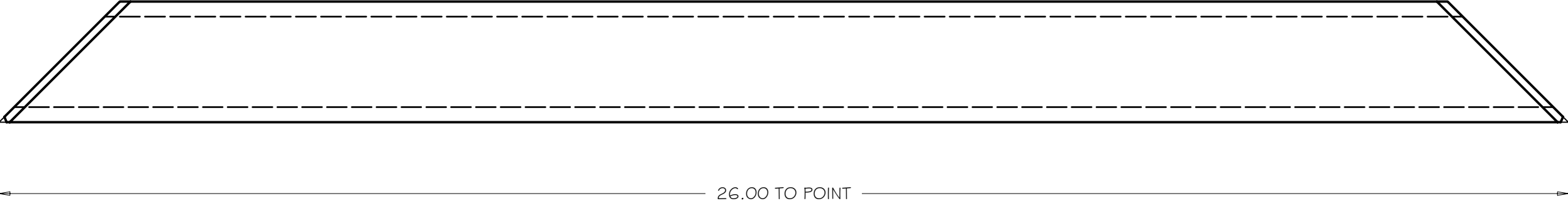
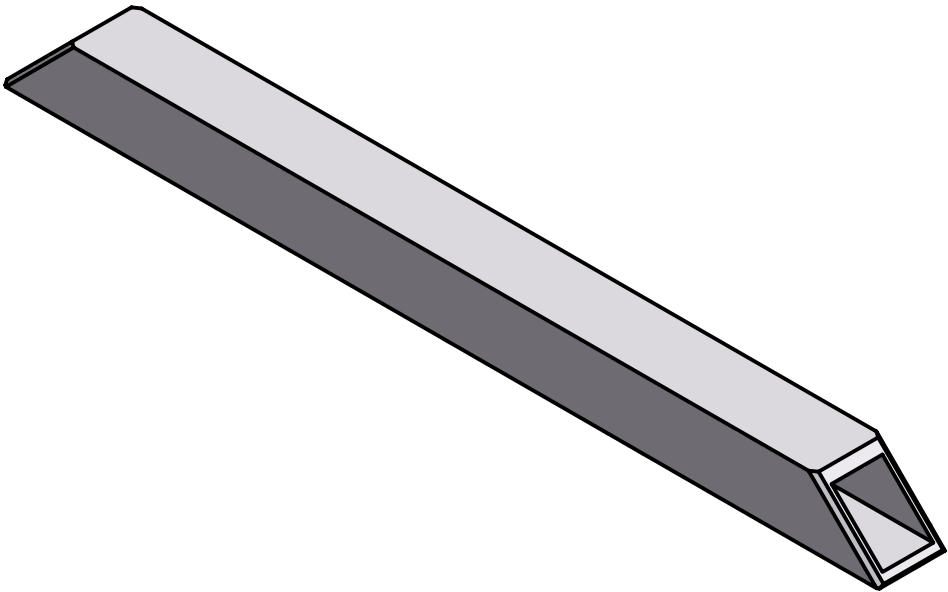

0.125 WELD CHAMFER, TYP

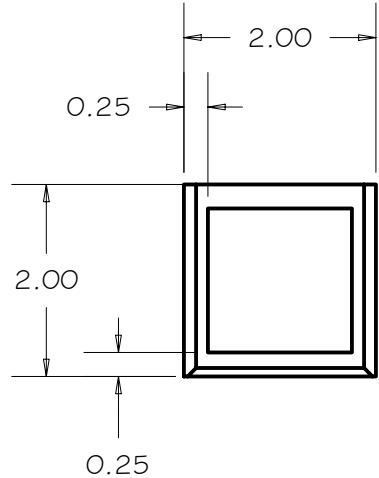

TOLERANCES UNLESS OTHERWISE NOTED:
 FRACTIONAL: 0"-6": ±1/64" 6"-24": ±1/32"
 24"+: ±1/16"
 DECIMAL: X.X: ±0.1000" X.XX: ±0.0100"
 X.XXX: ±0.0050" X.XXXX: ±0.0001"
 ANGLES: ±0.5° FINISH: 125 MICRO INCHES
 BREAK ALL SHARP EDGES & CORNERS 1/64" MAX



DRAWN: vernon 2/2/2005
 CHECKED:
 DESIGNED: vernon
 ENGINEER: vernon

Cassegrain ADC
 TITLE: FRAME

MATERIAL: ALUMINUM

FINISH: 2

QTY: 2

PROJECT CODE: A8048

DWG NO: A8053

REV: A

4

3

2

1