

| REV | DRWN | CHK'D | DATE | DESCRIPTION |
|-----|------|-------|----------|-------------|
| B | VRW | VRW | 12/17/04 | ADD HOLES |

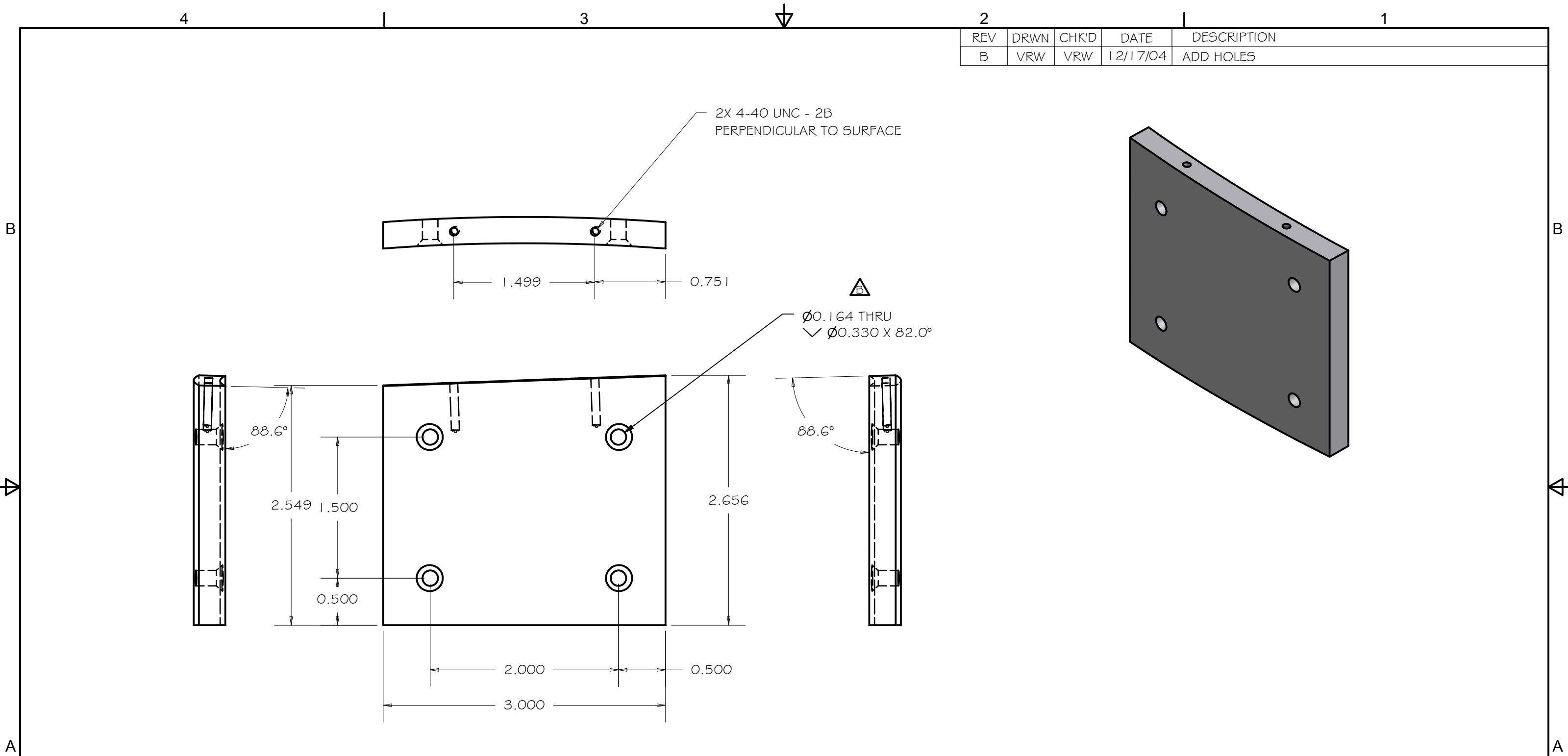

TOLERANCES UNLESS OTHERWISE NOTED:
 FRACTIONAL: 0"-6": ±1/64" 6"-24": ±1/32"
 24"+: ±1/16"
 DECIMAL: X.X: ±0.1000" X.XX: ±0.0100"
 X.XXX: ±0.0050" X.XXXX: ±0.0001"
 ANGLES: ±0.5° FINISH: 125 MICRO INCHES
 BREAK ALL SHARP EDGES & CORNERS 1/64" MAX

| | |
|----------|--------|
| MATERIAL | FINISH |
| STEEL | |



| | | |
|----------|--------|-----------|
| DRAWN | vernon | 2/23/2004 |
| CHECKED | | |
| DESIGNED | vernon | |
| ENGINEER | vernon | |
| QTY: 1 | | |

| | | | |
|--------------|--|--------|-----|
| PROJECT CODE | | DWG NO | REV |
| NEXT ASSY | | A205 1 | B |
| A2002 | | | 1/1 |

Cassegrain ADC

AXIAL CLAMP, AFT