

REV	DRWN	CHK'D	DATE	DESCRIPTION

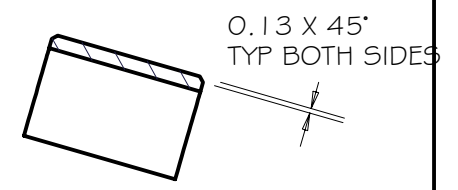

SECTION A-A
SCALE 1 / 5

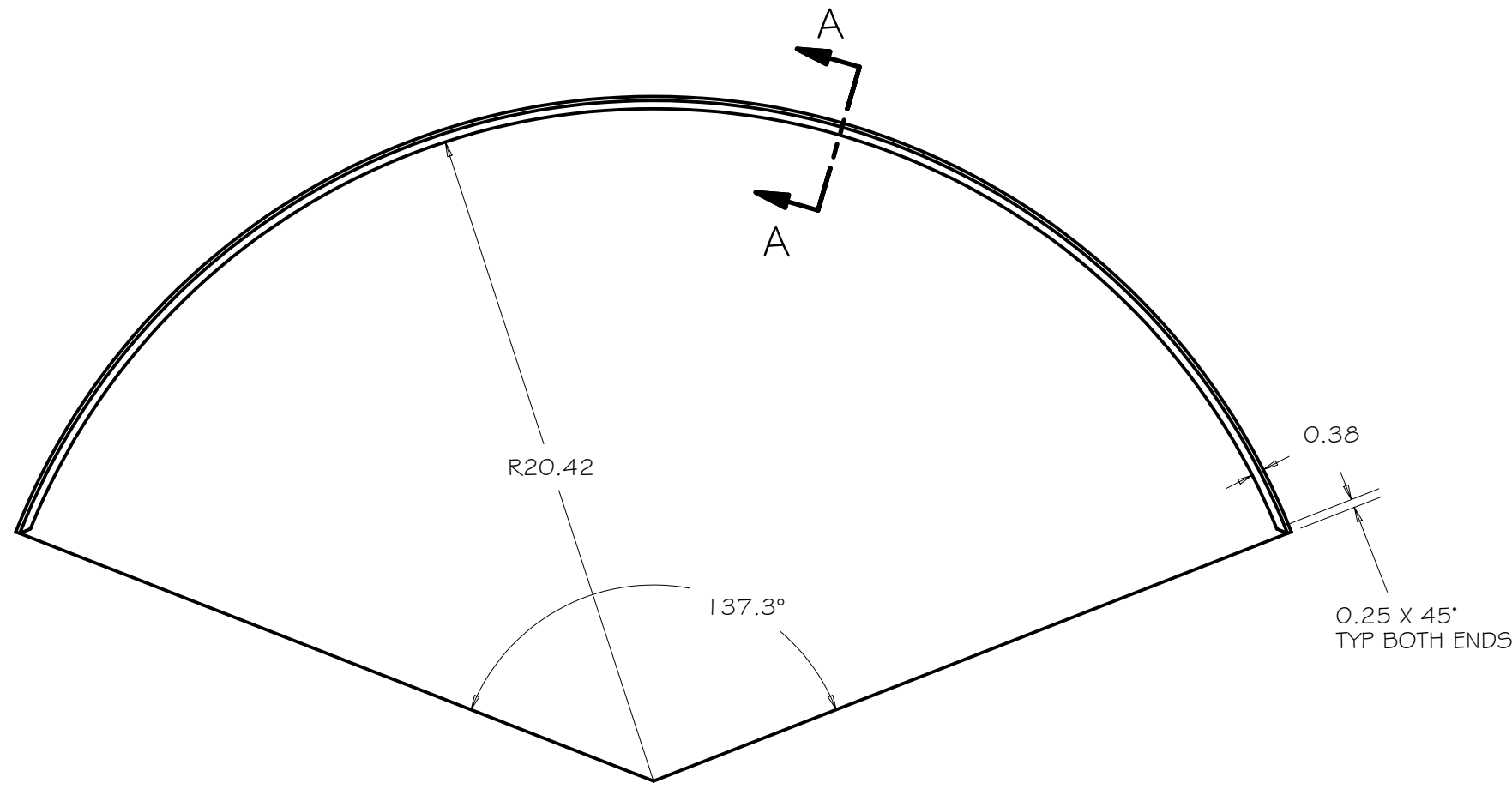
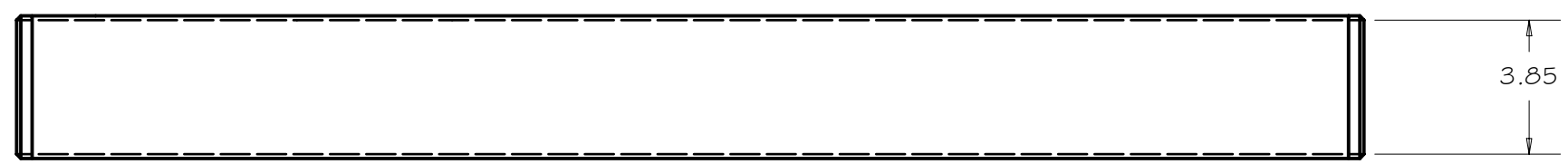

TOLERANCES UNLESS OTHERWISE NOTED:
 FRACTIONAL: 0"-6": ±1/64" 6"-24": ±1/32"
 24"+: ±1/16"
 DECIMAL: X.X: ±0.1000" X.XX: ±0.0100"
 X.XXX: ±0.0050" X.XXXX: ±0.0001"
 ANGLES: ±0.5° FINISH: 125 MICRO INCHES
 BREAK ALL SHARP EDGES & CORNERS 1/64" MAX

MATERIAL	FINISH
STEEL	



DRAWN	vernon	9/9/2003
CHECKED		
DESIGNED	vernon	
ENGINEER	vernon	
QTY: 1		

PROJECT CODE		DWG NO	REV
NEXT ASSY		A2033	A
A2030			1

Cassegrain ADC

LOWER CYLINDER, AFT

