

REV	DRWN	CHK'D	DATE	DESCRIPTION
B	VRW	VRW	7/1/04	LENGTHEN
C	VRW	VRW	9/1/04	ADD DIMENSIONS
D	VRW	VRW	9/8/04	REVISE FOR EASIER FABRICATION

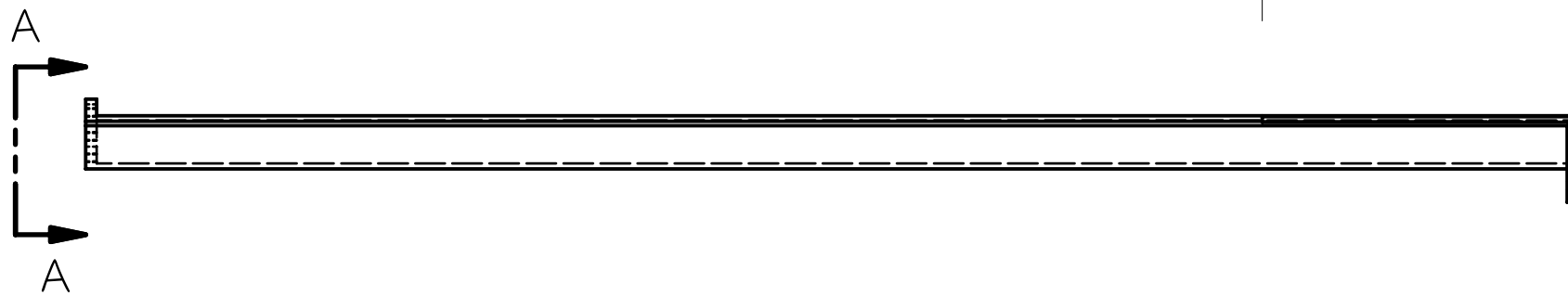
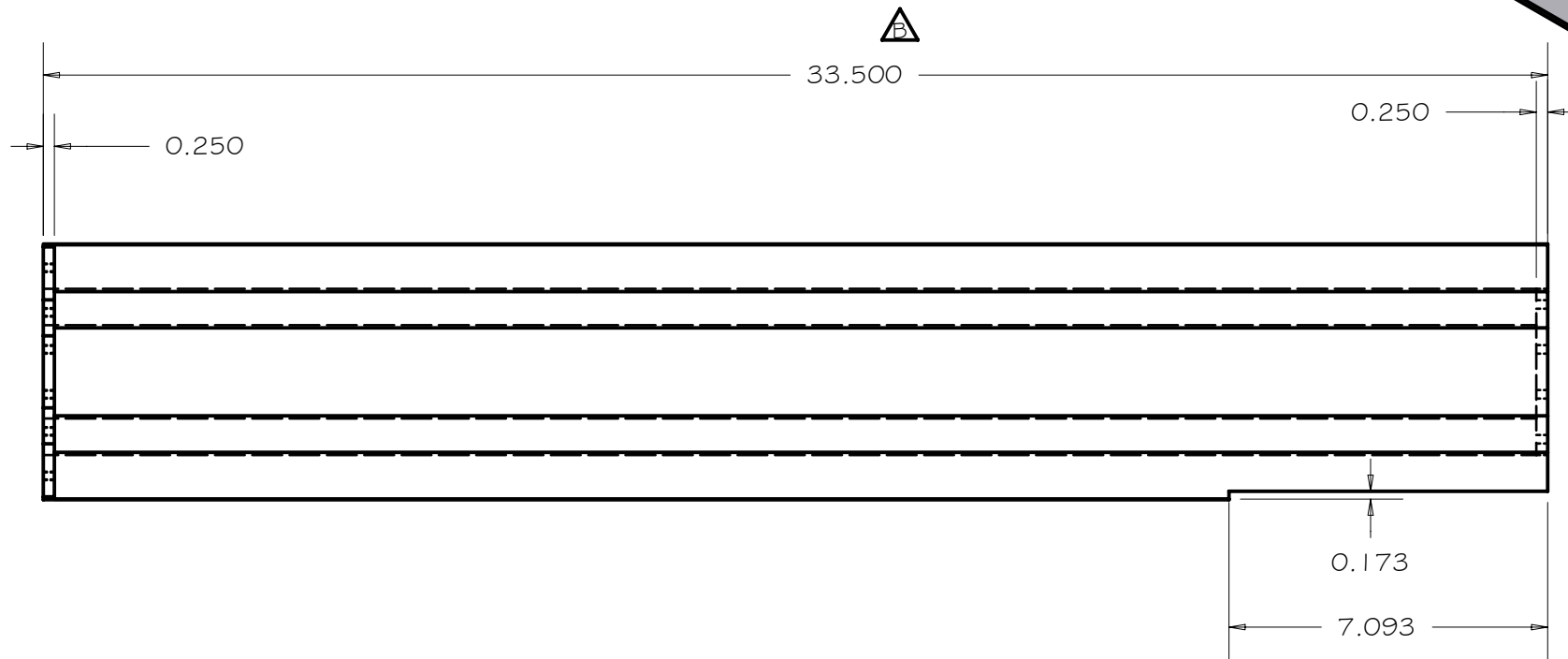
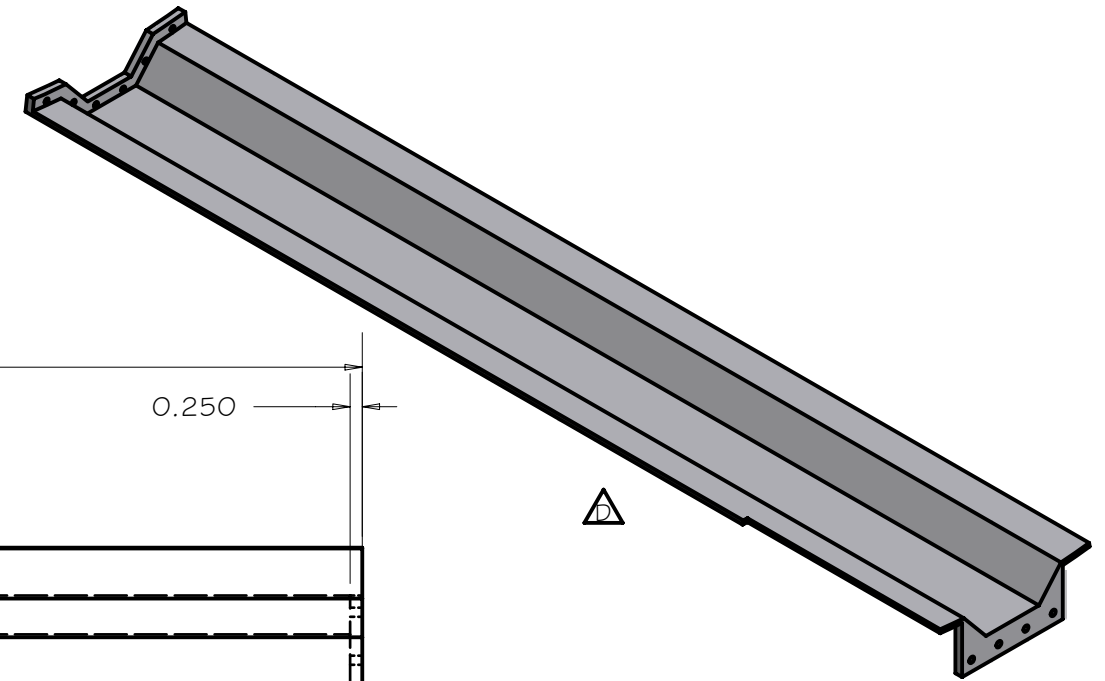

SCALE 1 / 4

TOLERANCES UNLESS OTHERWISE NOTED:
 FRACTIONAL: 0"-6": ±1/64" 6"-24": ±1/32"
 24"+: ±1/16"
 DECIMAL: X.X: ±0.1000" X.XX: ±0.0100"
 X.XXX: ±0.0050" X.XXXX: ±0.0001"
 ANGLES: ±0.5° FINISH: 125 MICRO INCHES
 BREAK ALL SHARP EDGES & CORNERS 1/64" MAX

MATERIAL: STEEL
 FINISH:

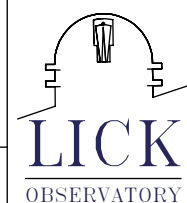

DRAWN: vernon 3/22/2004
 CHECKED:
 DESIGNED: vernon
 ENGINEER: vernon

QTY: 1

Cassegrain ADC

TITLE: BALL SCREW SHIELD, AFT

PROJECT CODE: A1100
 DWG NO: A1529
 REV: D 1/2

REV	DRWN	CHK'D	DATE	DESCRIPTION
-----	------	-------	------	-------------

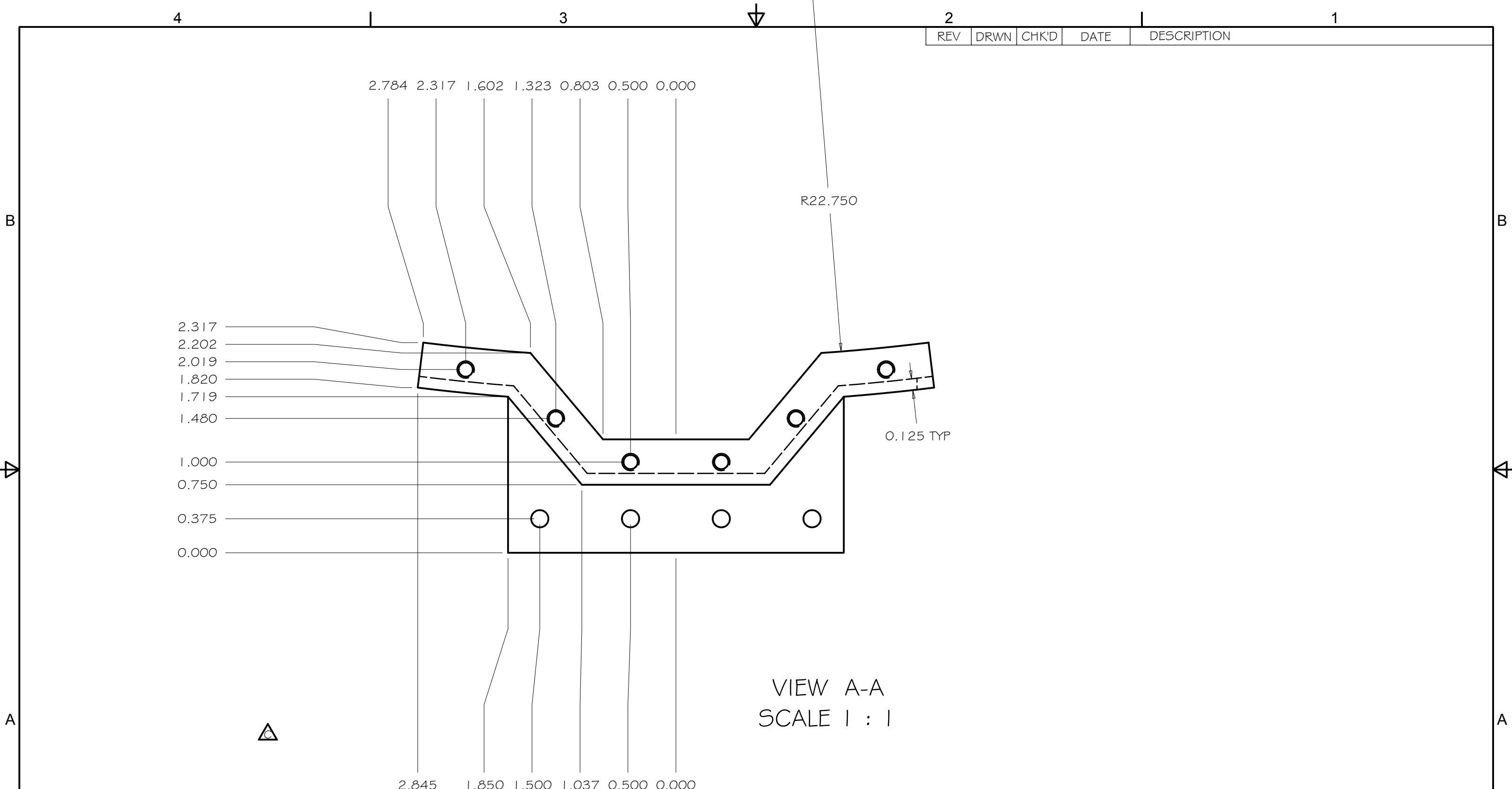

TOLERANCES UNLESS OTHERWISE NOTED:
 FRACTIONAL: 0"-6": ±1/64" 6"-24": ±1/32"
 24"+: ±1/16"
 DECIMAL: X.X: ±0.1000" X.XX: ±0.0100"
 X.XXX: ±0.0050" X.XXXX: ±0.0001"
 ANGLES: ±0.5° FINISH: 125 MICRO INCHES
 BREAK ALL SHARP EDGES & CORNERS 1/64" MAX

MATERIAL	FINISH
----------	--------



DRAWN	vernon	3/22/2004
CHECKED		
DESIGNED	vernon	
ENGINEER	vernon	

PROJECT CODE		DWG NO	REV
NEXT ASSY		A1529	D
A1100			2/2

Cassegrain ADC

BALL SCREW SHIELD, AFT