

REV	DRWN	CHK'D	DATE	DESCRIPTION

0.188

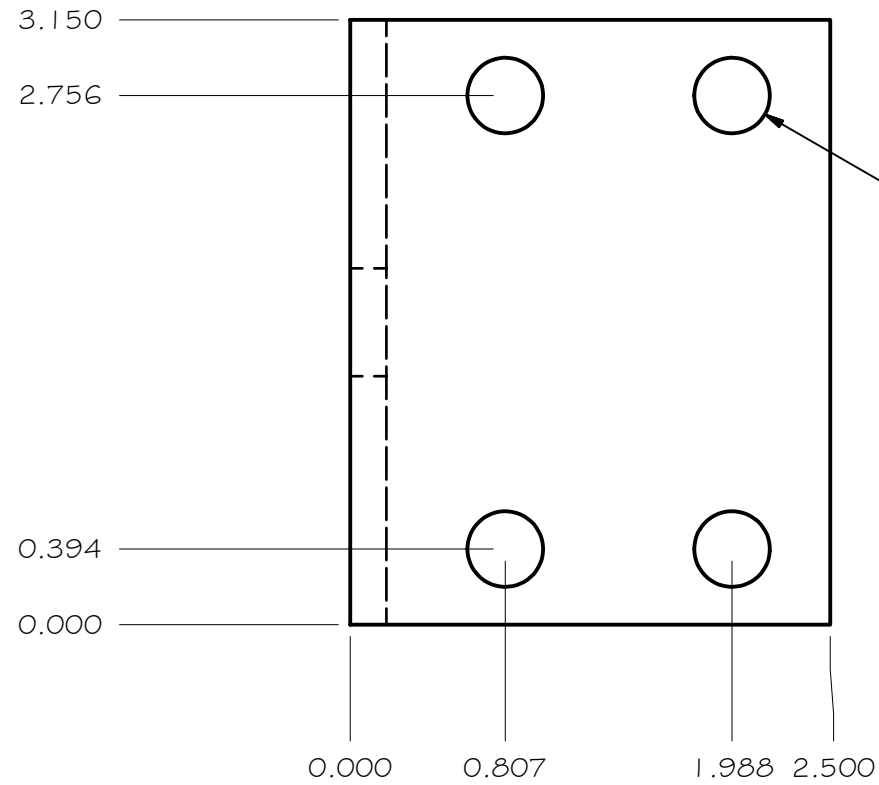

TOLERANCES UNLESS OTHERWISE NOTED:
 FRACTIONAL: 0"-6": ±1/64" 6"-24": ±1/32"
 24"+: ±1/16"
 DECIMAL: X.X: ±0.1000" X.XX: ±0.0100"
 X.XXX: ±0.0050" X.XXXX: ±0.0001"
 ANGLES: ±0.5° FINISH: 125 MICRO INCHES
 BREAK ALL SHARP EDGES & CORNERS 1/64" MAX

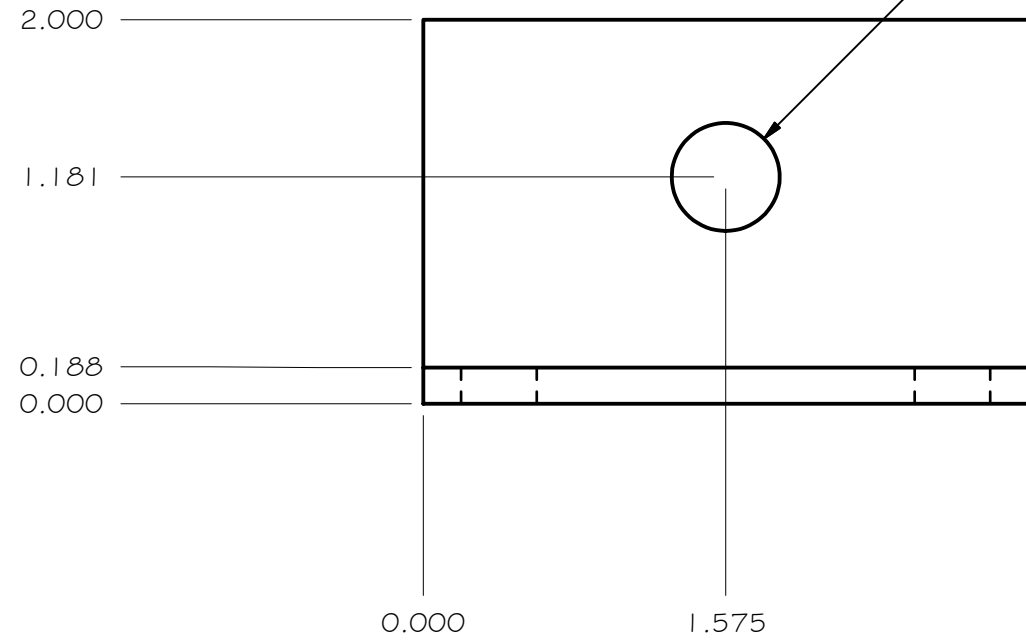
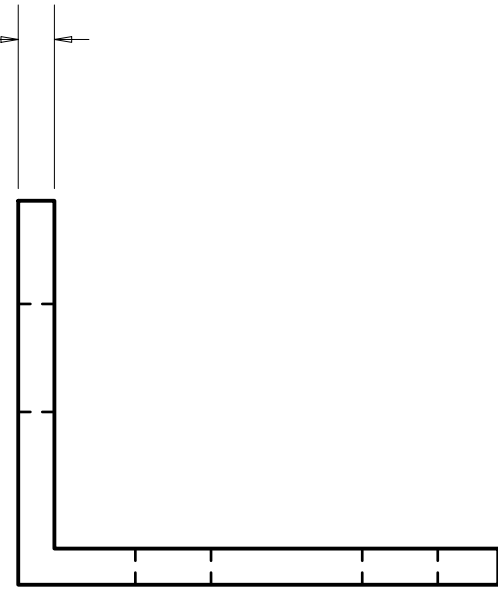
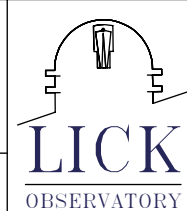

DRAWN	vernon	5/11/2005
CHECKED		
DESIGNED	vernon	
ENGINEER	vernon	
QTY: 3		

Cassegrain ADC	
TITLE HARDPOINT TELESCOPE SIDE	
PROJECT CODE A100	DWG NO A126
REV A	1/1

MATERIAL
ALUMINUM

FINISH

