

REV	DRWN	CHK'D	DATE	DESCRIPTION

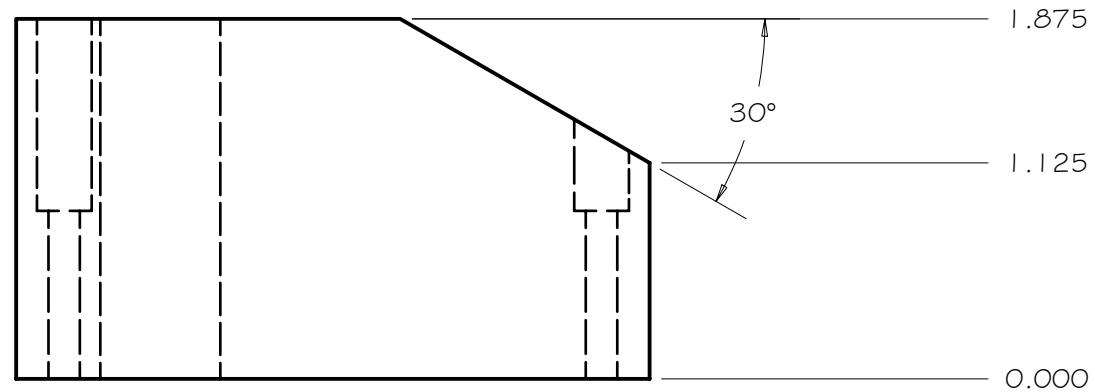
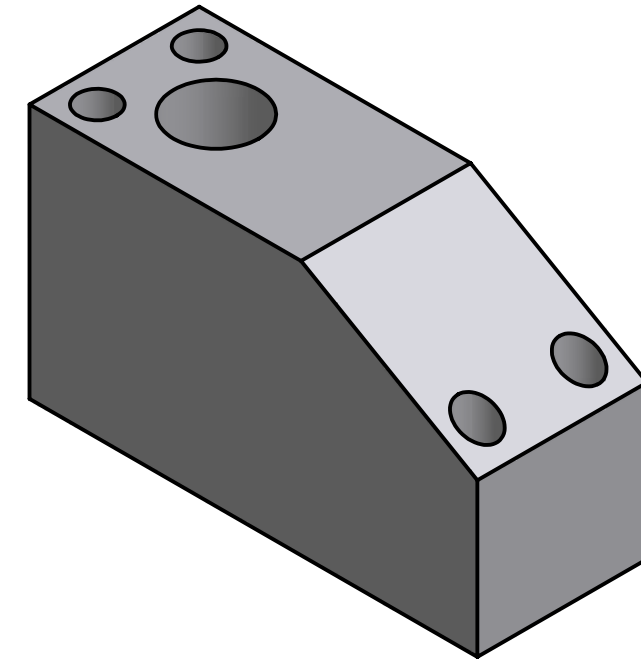
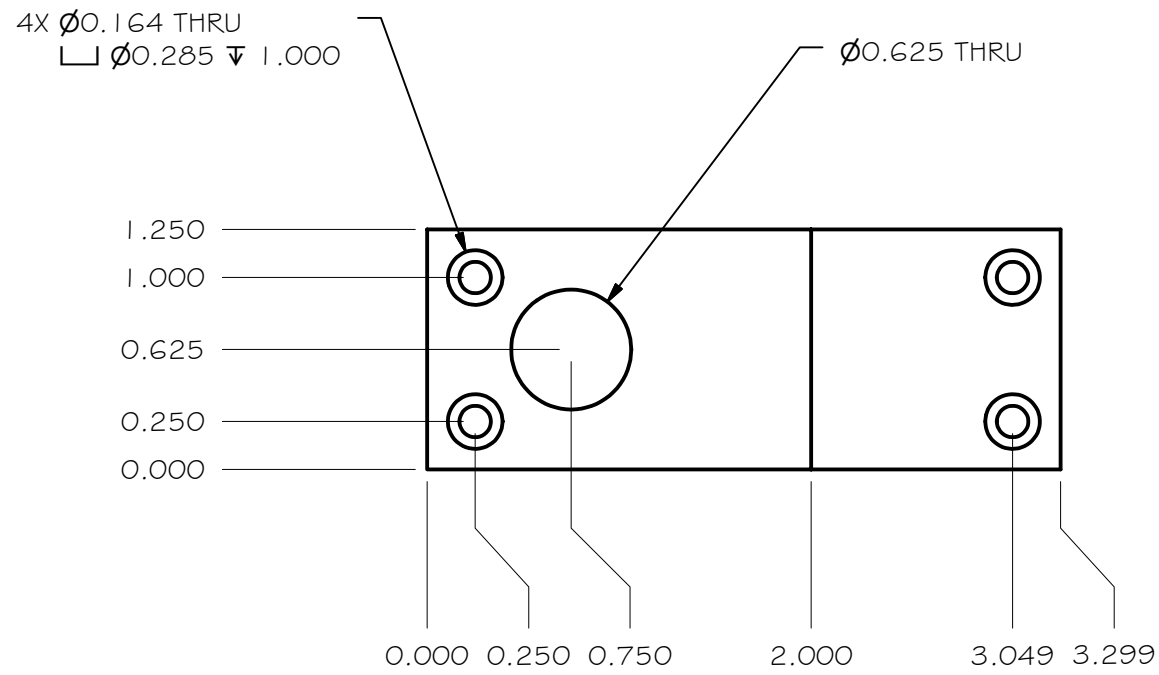

SCALE 1 : 1

TOLERANCES UNLESS OTHERWISE NOTED:
FRACTIONAL: 0"-6": $\pm 1/64$ " 6"-24": $\pm 1/32$ "
24"+: $\pm 1/16$ "
DECIMAL: X.X: ± 0.1000 " X.XX: ± 0.0100 "
X.XXX: ± 0.0050 " X.XXXX: ± 0.0001 "
ANGLES: $\pm 0.5^\circ$ FINISH: 125 MICRO INCHES
BREAK ALL SHARP EDGES & CORNERS 1/64" MAX

MATERIAL
ALUMINUM

FINISH



DRAWN vernon 5/10/2005
CHECKED
DESIGNED vernon
ENGINEER vernon

QTY: 2

Cassegrain ADC

TITLE
PICKUP HOLE

PROJECT CODE
NEXT ASSY
A100

DWG NO
A124

REV
A