

REV	DRWN	CHK'D	DATE	DESCRIPTION
B	VRW	VRW	6/21/04	CHANGE LENGTH

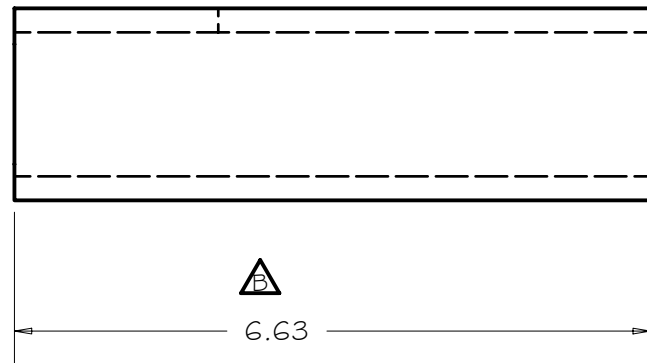

SCALE 1 / 2

TOLERANCES UNLESS OTHERWISE NOTED:  
 FRACTIONAL: 0"-6":  $\pm 1/64"$  6"-24":  $\pm 1/32"$   
 24"+:  $\pm 1/16"$   
 DECIMAL: X.X:  $\pm 0.1000"$  X.XX:  $\pm 0.0100"$   
 X.XXX:  $\pm 0.0050"$  X.XXXX:  $\pm 0.0001"$   
 ANGLES:  $\pm 0.5^\circ$  FINISH: 125 MICRO INCHES  
 BREAK ALL SHARP EDGES & CORNERS 1/64" MAX

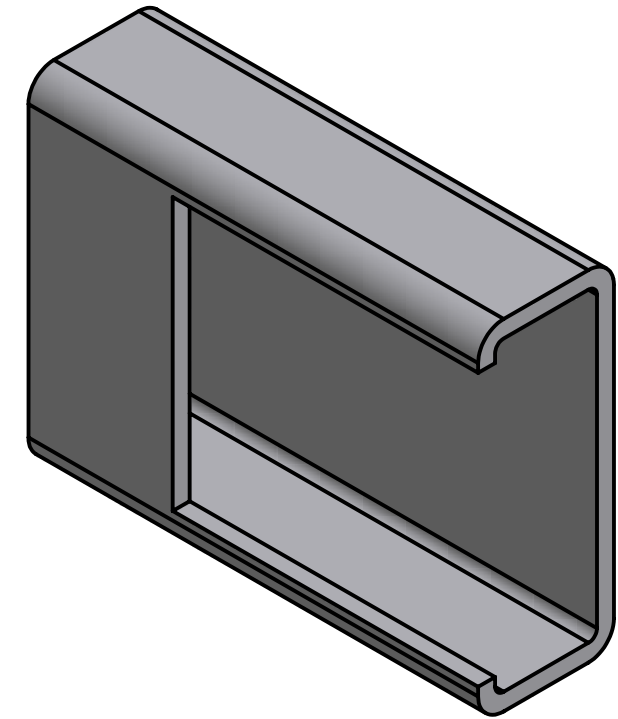
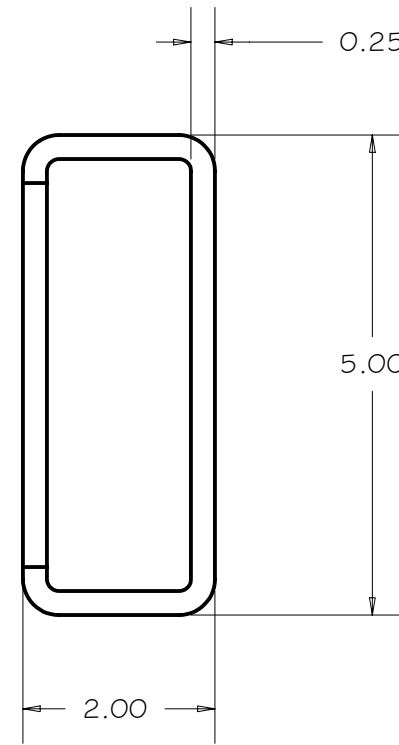
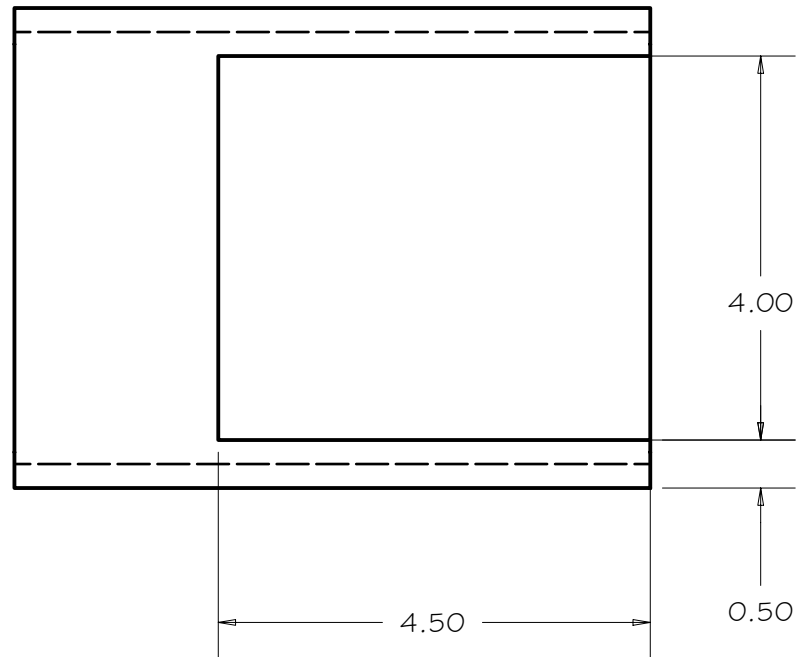

DRAWN	vernon	3/19/2004
CHECKED		
DESIGNED	vernon	
ENGINEER	vernon	

Cassegrain ADC	
TITLE HARDPOINT MOUNT SUPPORT	

MATERIAL	FINISH
STEEL TUBE	

QTY: 1
--------

PROJECT CODE	DWG NO	REV
	A1155	B
NEXT ASSY		1/1
A1150		