

REV	DRWN	CHK'D	DATE	DESCRIPTION
B	VRW	VRW	6/21/04	CHANGE ROLLERS & LENGTH
C	VRW	VRW	8/31/04	REVISE ROLLER POSITION

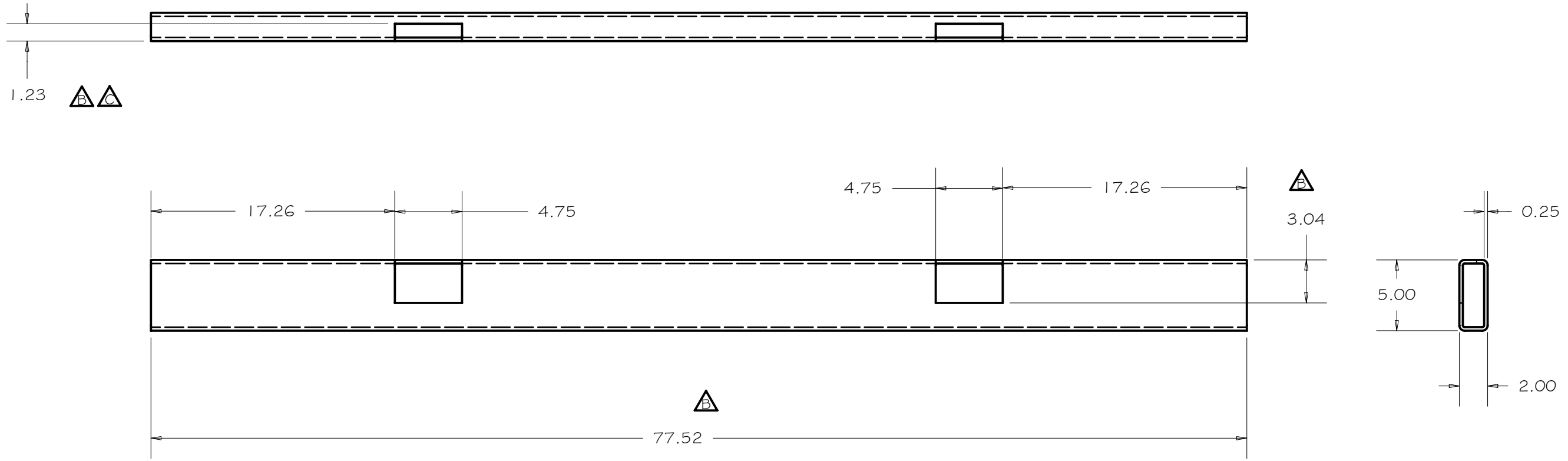

TOLERANCES UNLESS OTHERWISE NOTED:
 FRACTIONAL: 0"-6": ±1/64" 6"-24": ±1/32"
 24"+: ±1/16"
 DECIMAL: X.X: ±0.1000" X.XX: ±0.0100"
 X.XXX: ±0.0050" X.XXXX: ±0.0001"
 ANGLES: ±0.5° FINISH: 125 MICRO INCHES
 BREAK ALL SHARP EDGES & CORNERS 1/64" MAX



DRAWN	vernon	3/19/2004
CHECKED		
DESIGNED	vernon	
ENGINEER	vernon	
QTY: 1		

PROJECT CODE		DWG NO	REV
NEXT ASSY		A1131	C
A1130			1

Cassegrain ADC

SUPPORT TUBE. RIGHT

