

REV	DRWN	CHK'D	DATE	DESCRIPTION
B	VRW	VRW	6/21/04	CHANGE LENGTH

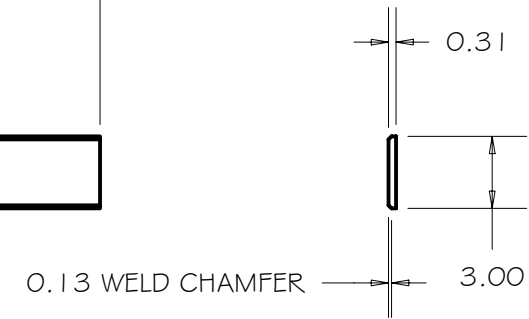

TOLERANCES UNLESS OTHERWISE NOTED:  
 FRACTIONAL: 0"-6": ±1/64" 6"-24": ±1/32"  
 24"+: ±1/16"  
 DECIMAL: X.X: ±0.1000" X.XX: ±0.0100"  
 X.XXX: ±0.0050" X.XXXX: ±0.0001"  
 ANGLES: ±0.5° FINISH: 125 MICRO INCHES  
 BREAK ALL SHARP EDGES & CORNERS 1/64" MAX

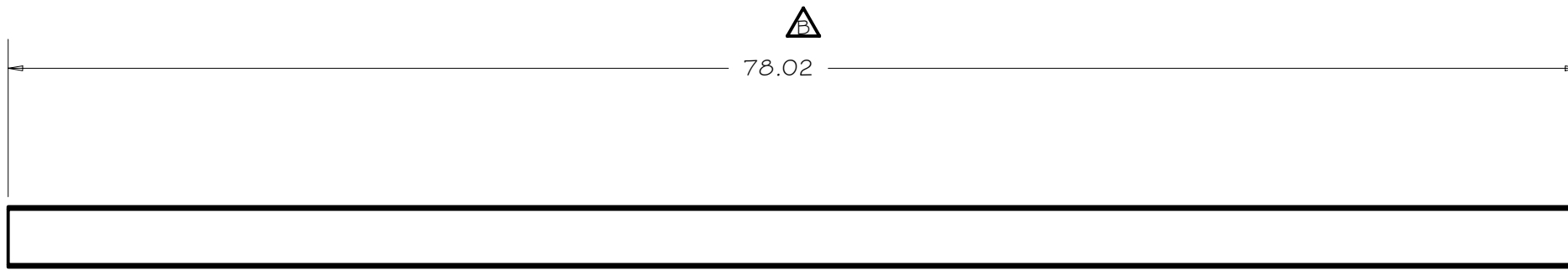
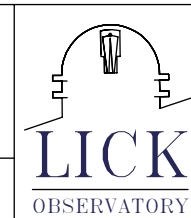

DRAWN	vernon	3/19/2004
CHECKED		
DESIGNED	vernon	
ENGINEER	vernon	

PROJECT CODE		DWG NO	
NEXT ASSY		REV	
A1110, A1130		B	

Cassegrain ADC

RAIL BASE

MATERIAL	FINISH
STEEL	

QTY: 2
--------

A1116
-------