

REV	DRWN	CHK'D	DATE	DESCRIPTION
B	VRW	VRW	6/21/04	CHANGE ROLLERS & LENGTH
C	VRW	VRW	8/31/04	REVISE ROLLER POSITION

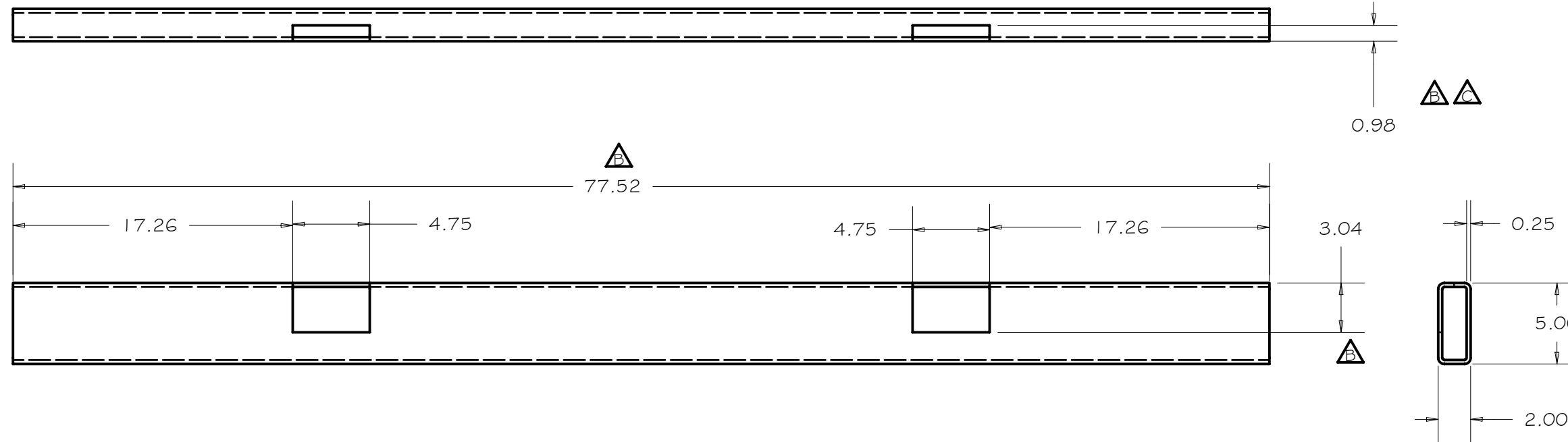

TOLERANCES UNLESS OTHERWISE NOTED:
 FRACTIONAL: 0"-6": ±1/64" 6"-24": ±1/32"
 24"+: ±1/16"
 DECIMAL: X.X: ±0.1000" X.XX: ±0.0100"
 X.XXX: ±0.0050" X.XXXX: ±0.0001"
 ANGLES: ±0.5° FINISH: 125 MICRO INCHES
 BREAK ALL SHARP EDGES & CORNERS 1/64" MAX

MATERIAL: STEEL TUBE
 FINISH:



DRAWN: vernon 9/3/2003
 CHECKED:
 DESIGNED: vernon
 ENGINEER: vernon

PROJECT CODE: Cassegrain ADC
 DWG NO: A1111

TITLE: SUPPORT TUBE, LEFT

PROJECT CODE: A1110
 DWG NO: A1111
 REV: C
 1/1