

REV	DRWN	CHK'D	DATE	DESCRIPTION

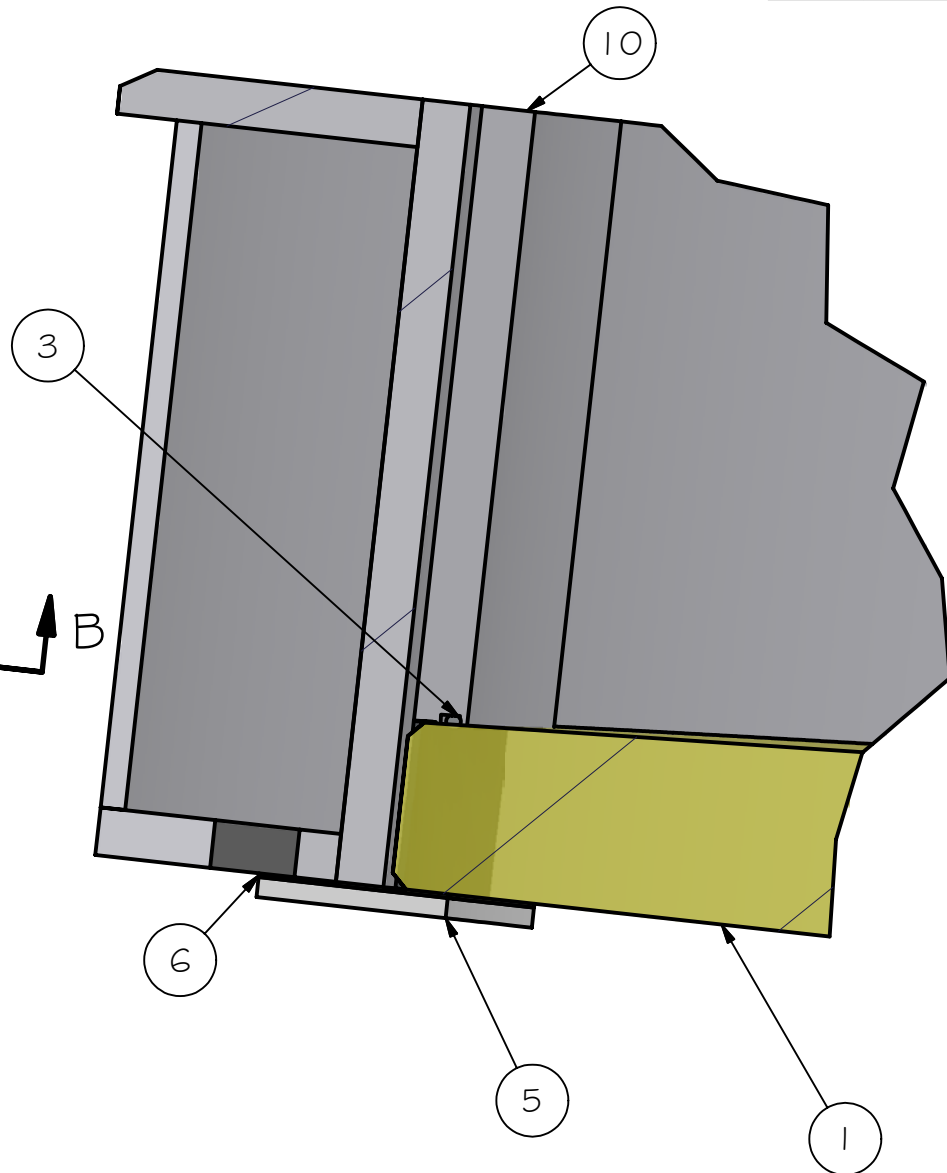
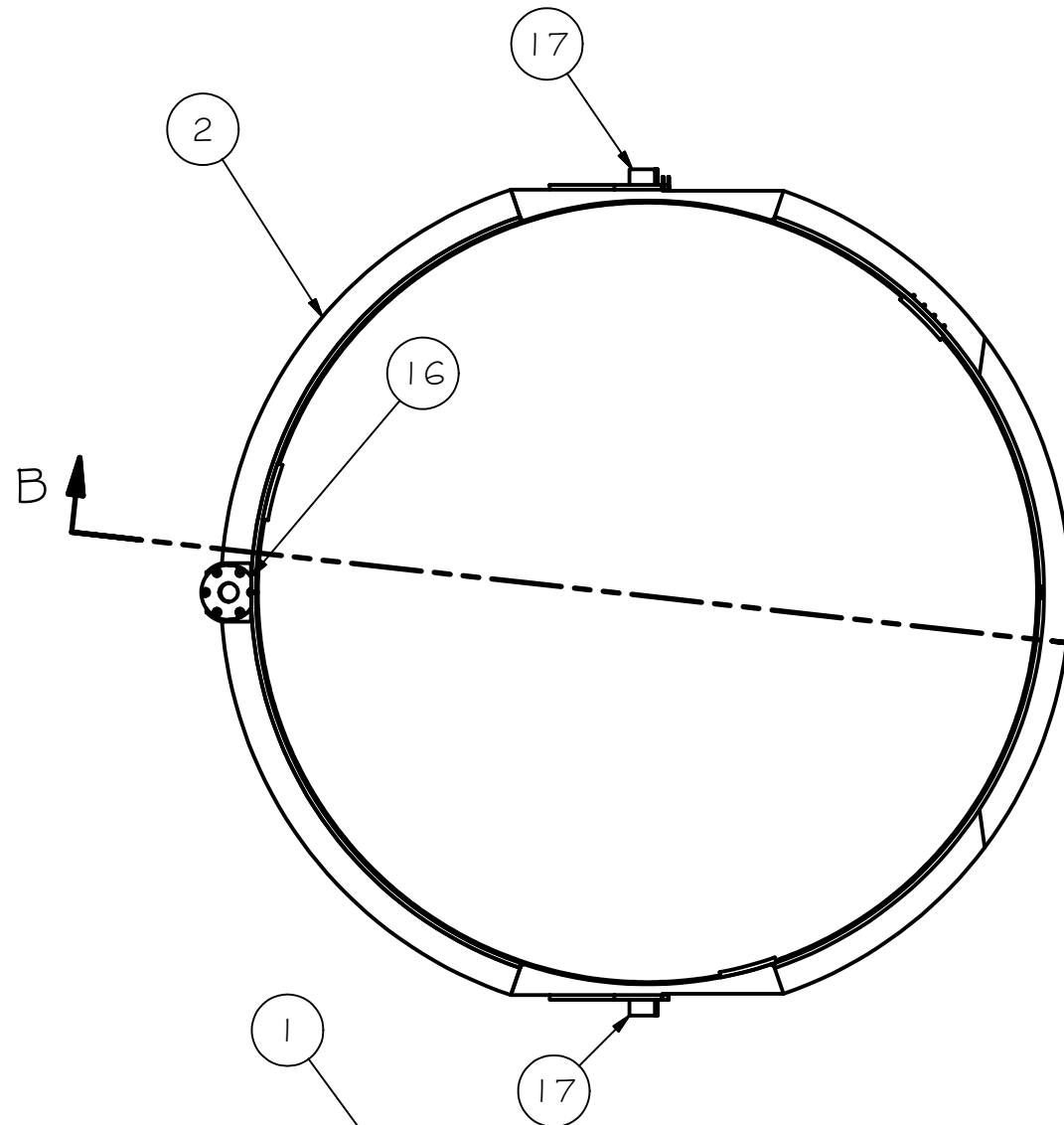

DETAIL C
SCALE 1 : 1

Parts List			
ITEM	QTY	PART NUMBER	DESCRIPTION
1	1	A2012	OPTIC ASSEMBLY
2	1	A2020	CELL WELDMENT, FORWARD
3	3	A2040	O-RING SECTION
4	1	A2042	SLIDE MOUNT
5	3	A2044	RETAINER, OPTIC, FWD
6	3	A2045	AXIAL SPACER, FWD
7	1	A2046	FIDUCAL TAB, LONG
8	1	A2047	FIDUCAL TAB, SHORT
9	1	A2048	SLIDE MOUNT
10	1	A2053	AXIAL CLAMP, FWD
11	1	A2054	AXIAL CLAMP, FWD
12	1	A2055	AXIAL CLAMP, FWD
13	1	A2064	RADIAL SPACER, FWD
14	1	A2065	RADIAL SPACER, FWD
15	1	A2066	RADIAL SPACER, FWD
16	1	BALL NUT	THK BNF-2505-5
17	4	BALL SLIDE	THK SHS-20-V SLIDE

NOTES:
1) GLUE ITEMS 3, 13, 14 & 15 IN POSITION WITH CYANOACRYLATE GLUE

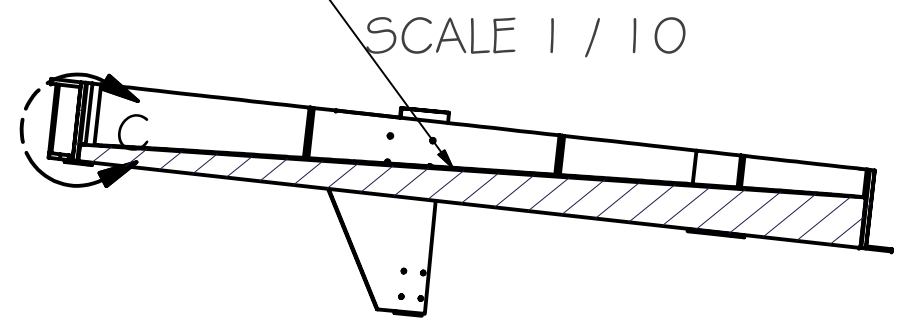

SECTION B-B
SCALE 1 / 10

TOLERANCES UNLESS OTHERWISE NOTED:	
FRACTIONAL:	0"-6": ±1/64" 6"-24": ±1/32" 24"+: ±1/16"
DECIMAL:	X.X: ±0.1000" X.XX: ±0.0100" X.XXX: ±0.0050" X.XXXX: ±0.0001"
ANGLES: ±0.5° FINISH: 125 MICRO INCHES BREAK ALL SHARP EDGES & CORNERS 1/64" MAX	
MATERIAL	FINISH



DRAWN	vernon	7/22/2003
CHECKED		
DESIGNED	vernon	
ENGINEER		
QTY: 1		

Cassegrain ADC	
TITLE CELL ASSEMBLY, FORWARD	
PROJECT CODE	DWG NO
A0001	A2001
NEXT ASSY	REV
	A