

REV	DRWN	CHK'D	DATE	DESCRIPTION

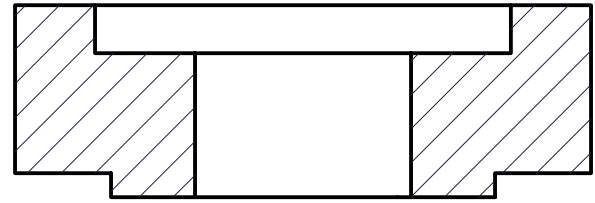

SECTION A-A
SCALE 1 : 1

4X $\varnothing 0.190$ THRU
 $\sqsubset \varnothing 0.327 \nabla 0.230$

$\varnothing 1.125$ THRU
 $\sqsubset \varnothing 2.165 \nabla 0.250$

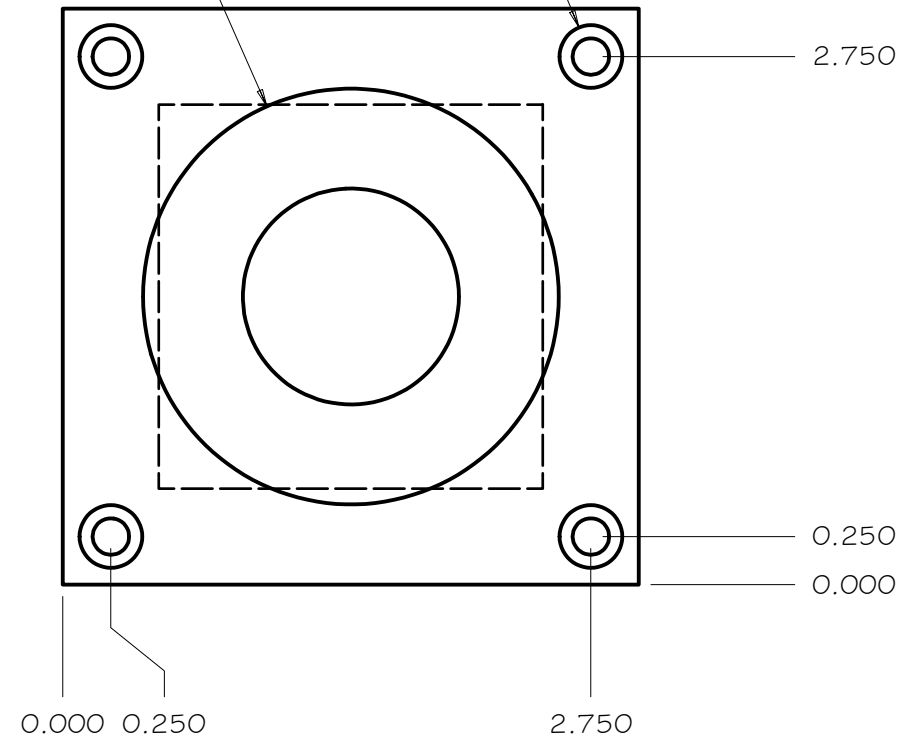
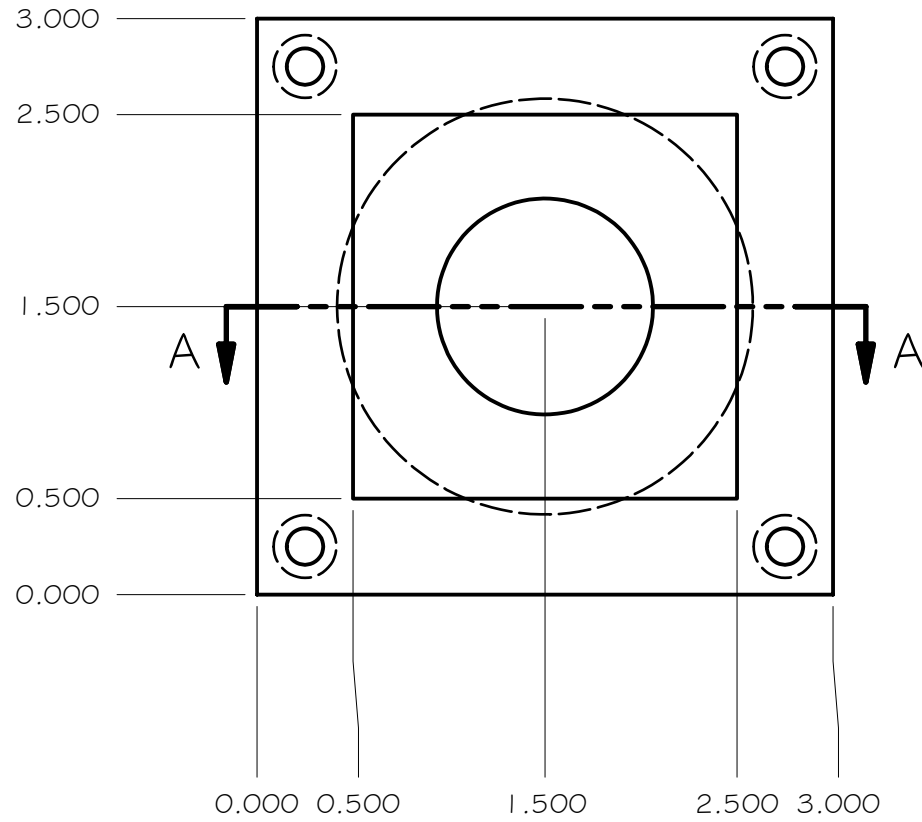
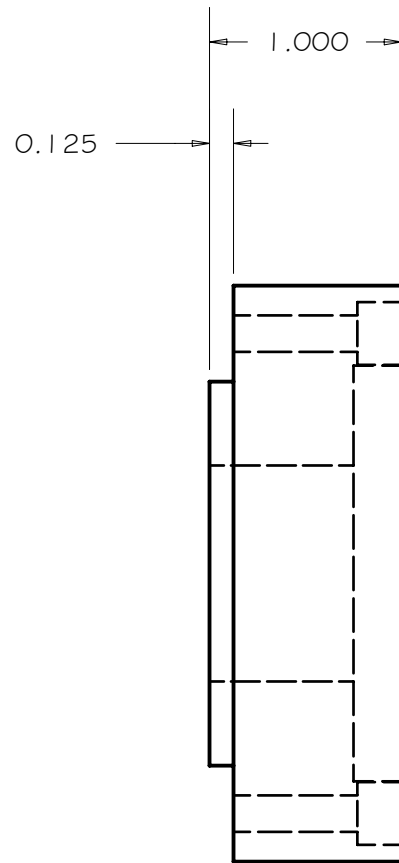
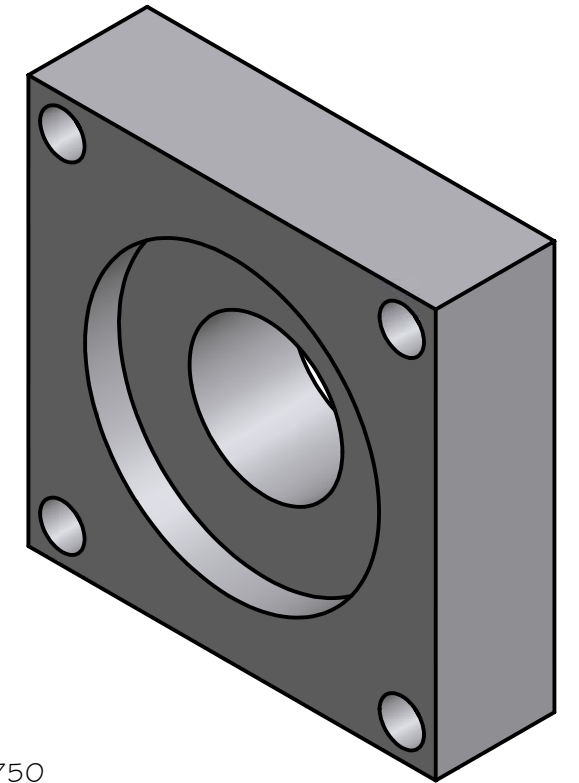

TOLERANCES UNLESS OTHERWISE NOTED:
 FRACTIONAL: 0"-6": $\pm 1/64$ " 6"-24": $\pm 1/32$ "
 24"+: $\pm 1/16$ "
 DECIMAL: X.X: ± 0.1000 " X.XX: ± 0.0100 "
 X.XXX: ± 0.0050 " X.XXXX: ± 0.0001 "
 ANGLES: $\pm 0.5^\circ$ FINISH: 125 MICRO INCHES
 BREAK ALL SHARP EDGES & CORNERS 1/64" MAX

MATERIAL: STEEL
 FINISH: 2



DRAWN: vernon
 CHECKED: 3/29/2004
 DESIGNED: vernon
 ENGINEER: vernon

QTY: 1

PROJECT CODE: A5001
 DWG NO: A5046
 TITLE: BEARING MOUNT
 REV: A