

4

3

2

1

REV	DRWN	CHK'D	DATE	DESCRIPTION
-----	------	-------	------	-------------

B

B

A

A

A

A

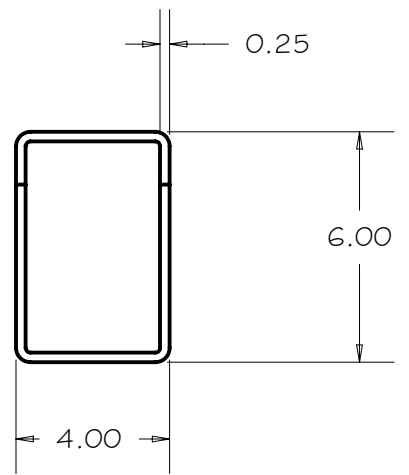
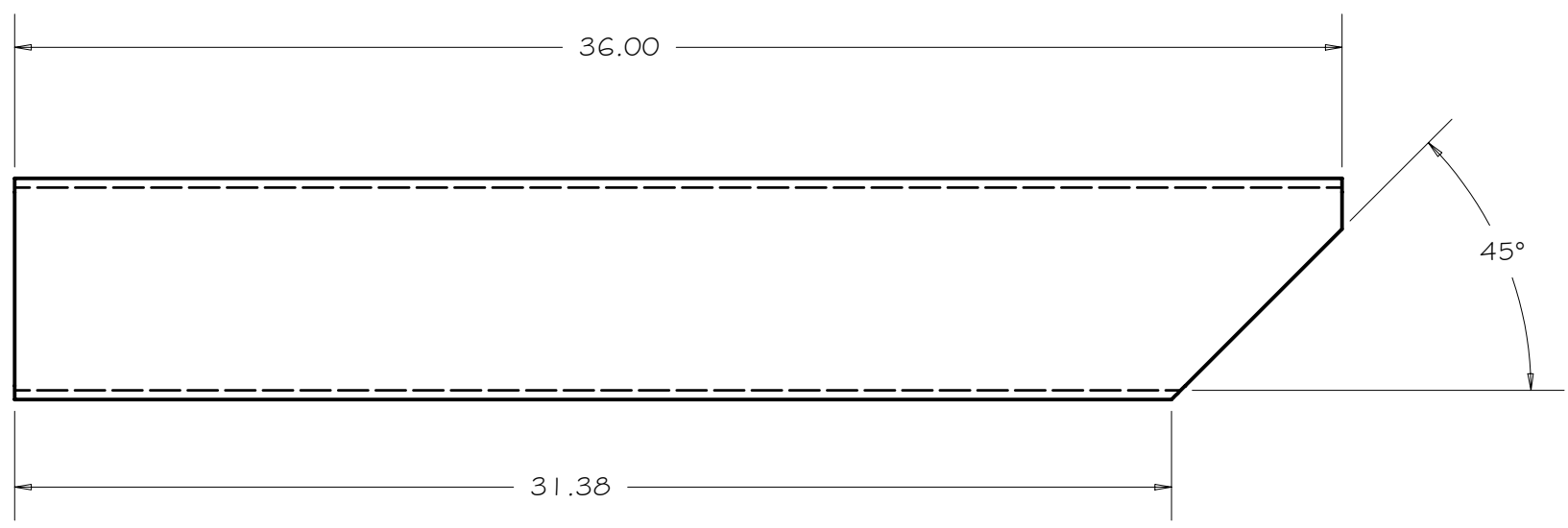

TOLERANCES UNLESS OTHERWISE NOTED:  
 FRACTIONAL: 0"-6": ±1/64" 6"-24": ±1/32"  
 24"+: ±1/16"  
 DECIMAL: X.X: ±0.1000" X.XX: ±0.0100"  
 X.XXX: ±0.0050" X.XXXX: ±0.0001"  
 ANGLES: ±0.5° FINISH: 125 MICRO INCHES  
 BREAK ALL SHARP EDGES & CORNERS 1/64" MAX

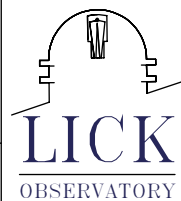

MATERIAL	FINISH
STEEL TUBE	

DRAWN	vernon	3/29/2004
CHECKED		
DESIGNED	vernon	
ENGINEER	vernon	

Cassegrain ADC	
TITLE	
BEAM, UPRIGHT	

QTY: 2
--------

PROJECT CODE	DWG NO	REV
A5020	A5022	A
NEXT ASSY		1

4

3

2

1