

REV	DRWN	CHK'D	DATE	DESCRIPTION

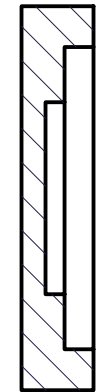

SECTION A-A
SCALE 1 : 1

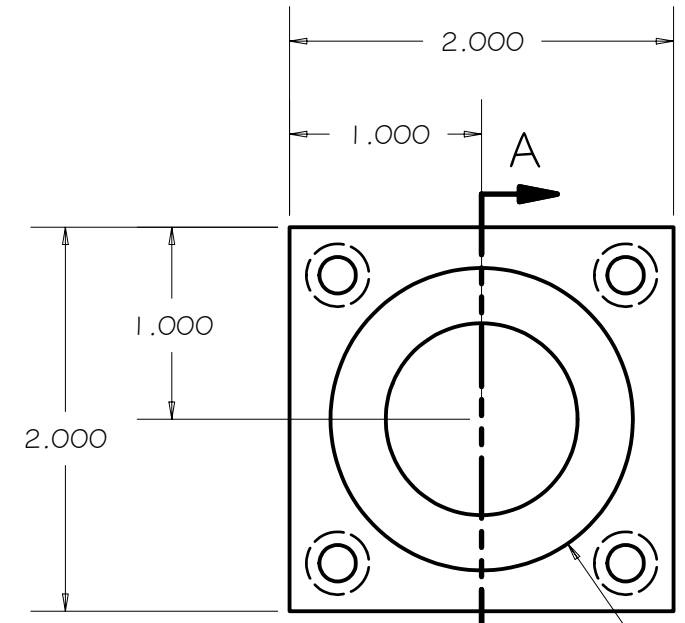

SCALE 1 : 1

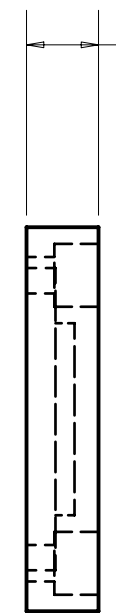

0.375

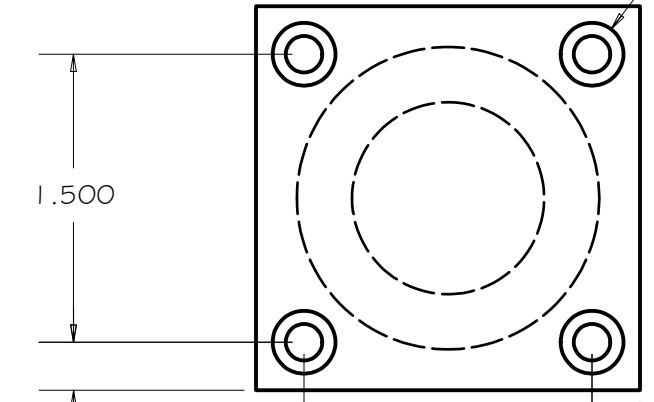

4X \varnothing 0.190 THRU
 \square \varnothing 0.327 ∇ 0.230

\varnothing 1.000 ∇ 0.250
 \square \varnothing 1.575 ∇ 0.151

TOLERANCES UNLESS OTHERWISE NOTED:
 FRACTIONAL: 0"-6": \pm 1/64" 6"-24": \pm 1/32"
 24"+: \pm 1/16"
 DECIMAL: X.X: \pm 0.1000" X.XX: \pm 0.0100"
 X.XXX: \pm 0.0050" X.XXXX: \pm 0.0001"
 ANGLES: \pm 0.5° FINISH: 125 MICRO INCHES
 BREAK ALL SHARP EDGES & CORNERS 1/64" MAX

MATERIAL	FINISH
STEEL	



DRAWN	vernon	3/22/2004
CHECKED		
DESIGNED	vernon	
ENGINEER	vernon	

QTY: 1

PROJECT CODE	DWG NO	REV
	A1220	A
NEXT ASSY		
A1000		

Cassegrain ADC

BALL SCREW CAP, AFT