

4

3

2

1

REV	DRWN	CHK'D	DATE	DESCRIPTION
-----	------	-------	------	-------------

B

B

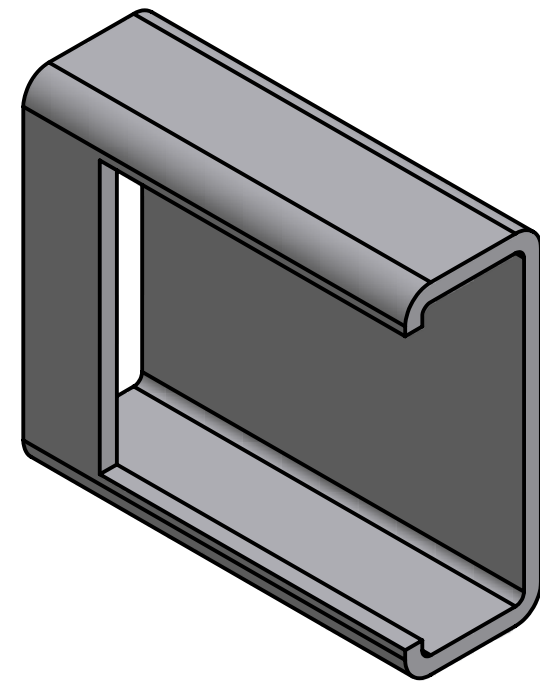
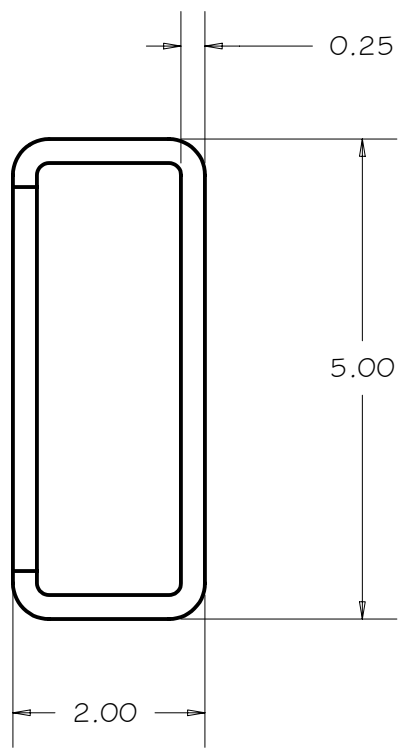
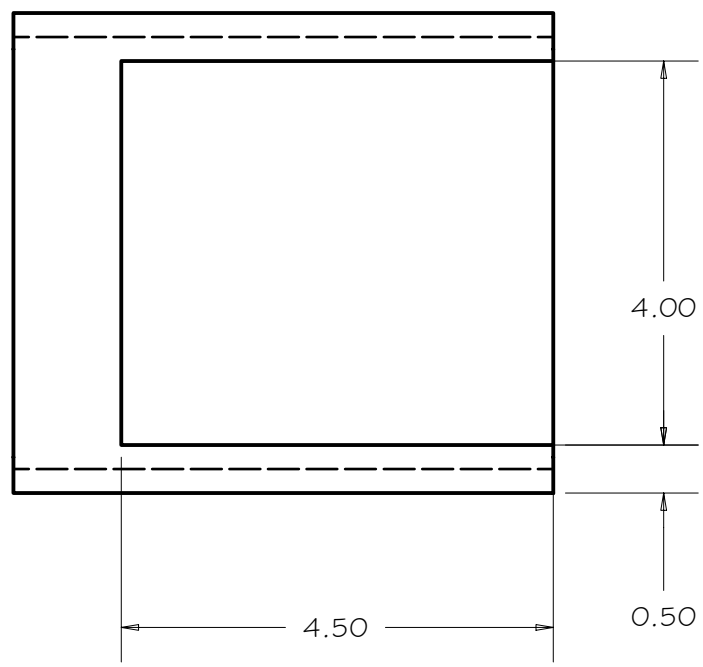

A

A

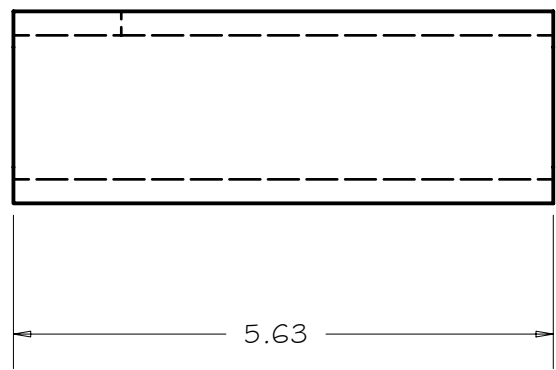

SCALE 1 / 2

TOLERANCES UNLESS OTHERWISE NOTED:  
 FRACTIONAL: 0"-6": ±1/64" 6"-24": ±1/32"  
 24"+: ±1/16"  
 DECIMAL: X.X: ±0.1000" X.XX: ±0.0100"  
 X.XXX: ±0.0050" X.XXXX: ±0.0001"  
 ANGLES: ±0.5° FINISH: 125 MICRO INCHES  
 BREAK ALL SHARP EDGES & CORNERS 1/64" MAX

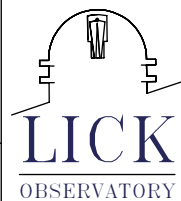

DRAWN	vernon	3/19/2004
CHECKED		
DESIGNED	vernon	
ENGINEER	vernon	

Cassegrain ADC

TITLE  
HARDPOINT MOUNT SUPPORT

MATERIAL	FINISH
STEEL TUBE	

QTY: 1

PROJECT CODE	DWG NO
	A1155

REV	A
1	1

4

3

2

1

A

A