

REV	DRWN	CHK'D	DATE	DESCRIPTION
B	VRW	VRW	7/26/05	ADD HOLES FOR LLNL FIXTURE

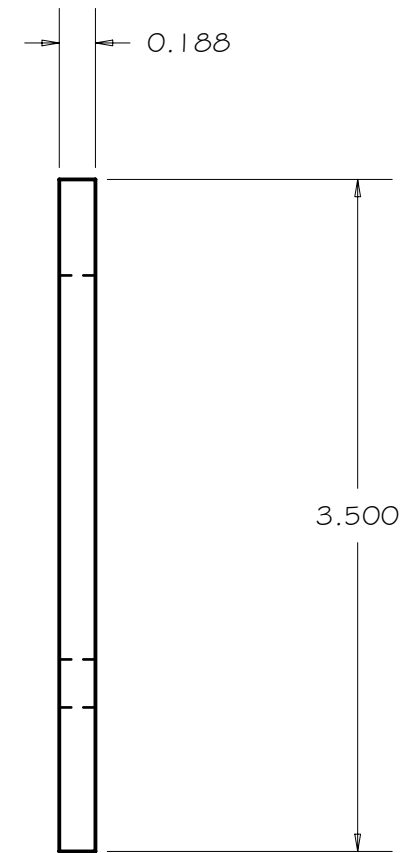
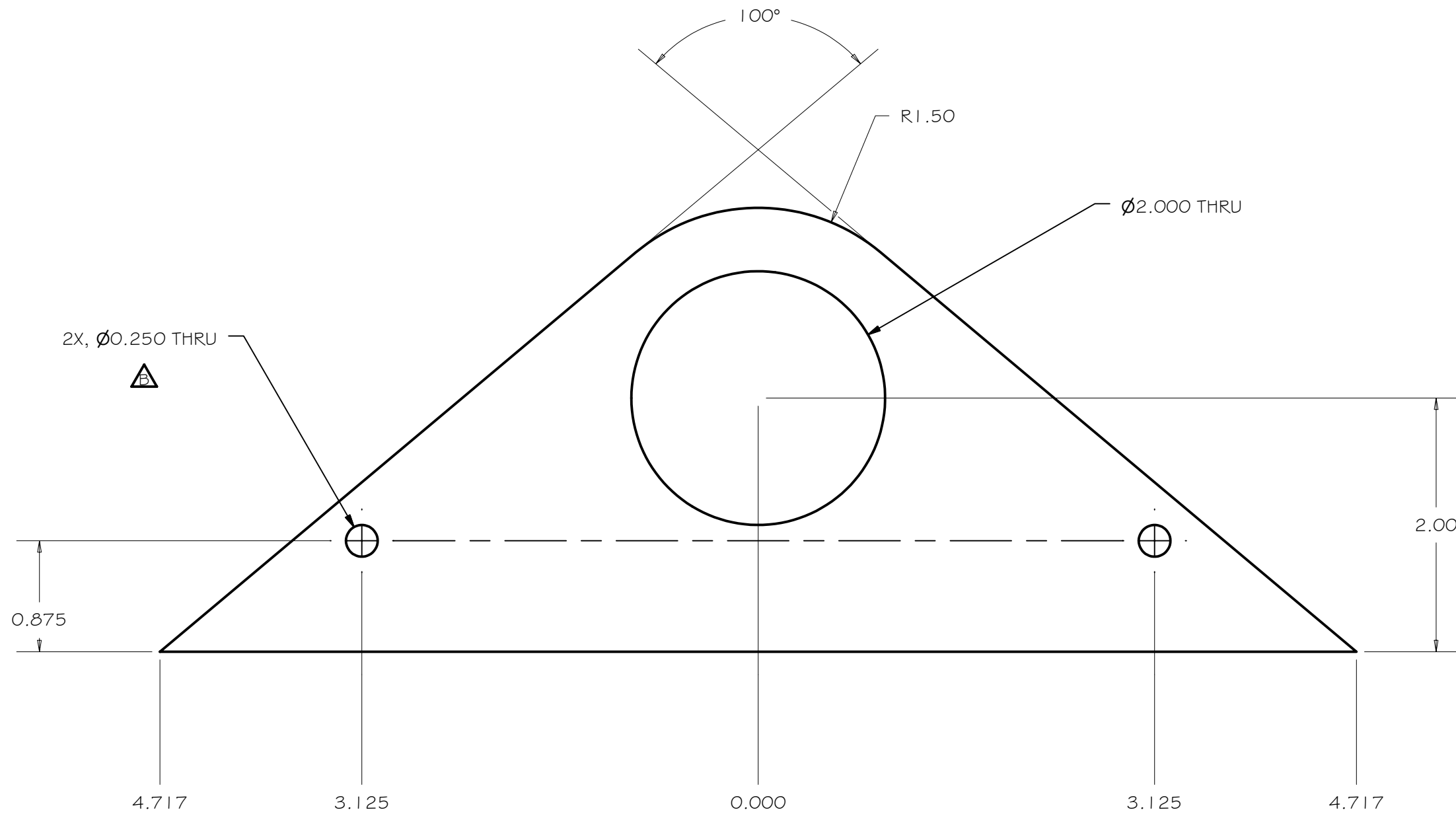

SCALE 1 : 1

TOLERANCES UNLESS OTHERWISE NOTED:
 FRACTIONAL: 0"-6": ±1/64" 6"-24": ±1/32"
 24"+: ±1/16"
 DECIMAL: X.X: ±0.1000" X.XX: ±0.0100"
 X.XXX: ±0.0050" X.XXXX: ±0.0001"
 ANGLES: ±0.5° FINISH: 125 MICRO INCHES
 BREAK ALL SHARP EDGES & CORNERS 1/64" MAX

MATERIAL: STEEL
 FINISH:

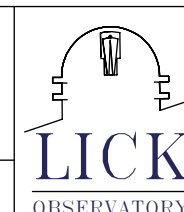

DRAWN: vernon
 CHECKED:
 DESIGNED: vernon
 ENGINEER: VRW
 QTY: 1

1/24/2005
 Sol-Gel Facility
 TITLE: ADC SPREADER, EYE
 PROJECT CODE: SG4116
 DWG NO: SG4115
 REV B