

REV	DRWN	CHK'D	DATE	DESCRIPTION

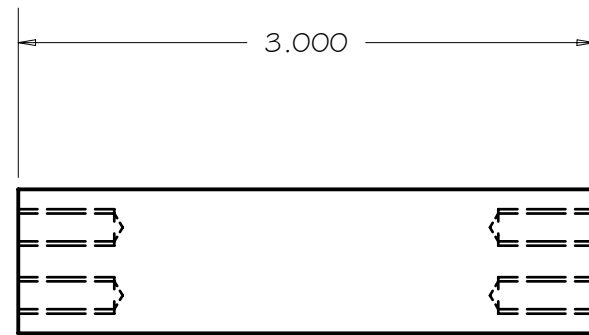

SCALE 1 : 1

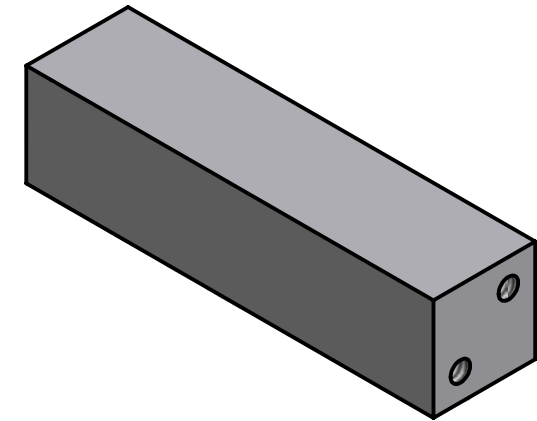
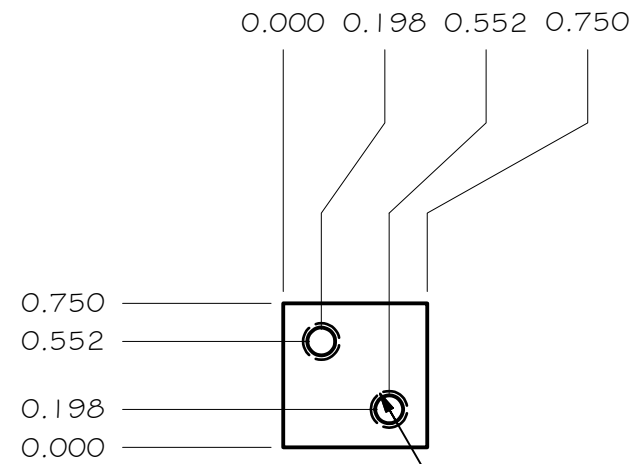

2X 10-24 UNC - 2B

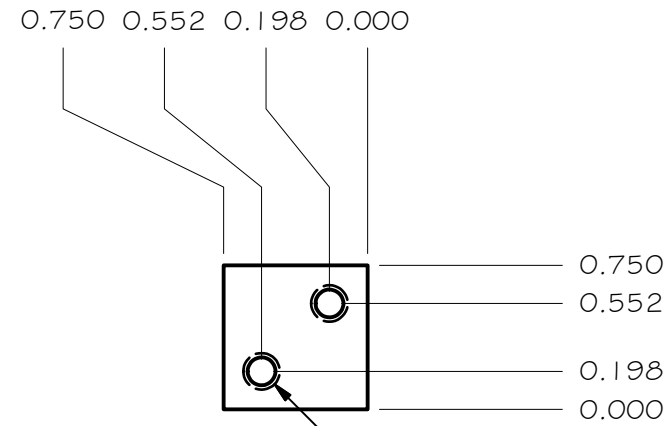

2X 10-24 UNC - 2B

TOLERANCES UNLESS OTHERWISE NOTED:
 FRACTIONAL: 0"-6": ±1/64" 6"-24": ±1/32"
 24"+: ±1/16"
 DECIMAL: X.X: ±0.1000" X.XX: ±0.0100"
 X.XXX: ±0.0050" X.XXXX: ±0.0001"
 ANGLES: ±0.5° FINISH: 125 MICRO INCHES
 BREAK ALL SHARP EDGES & CORNERS 1/64" MAX

MATERIAL	FINISH
STEEL	2



DRAWN	vernon	2/16/2005
CHECKED		
DESIGNED	vernon	
ENGINEER	vernon	

QTY: 2

PROJECT CODE		DWG NO	REV
NEXT ASSY		A8092	A
A8090			1

Cassegrain ADC

POST

A8092