

4

3

2

1

REV	DRWN	CHKD	DATE	DESCRIPTION

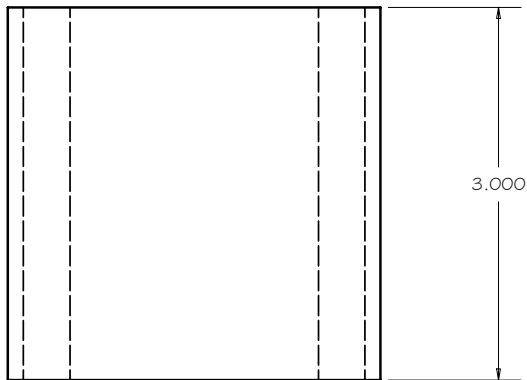

3.000

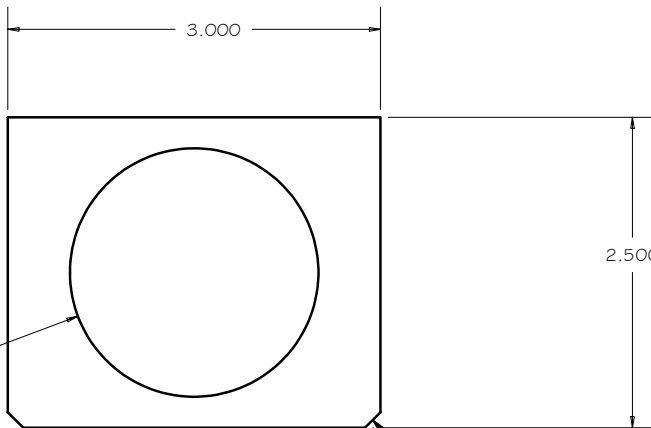

3.000

2.500

∅2.000

1/8 WELD CHAMFER

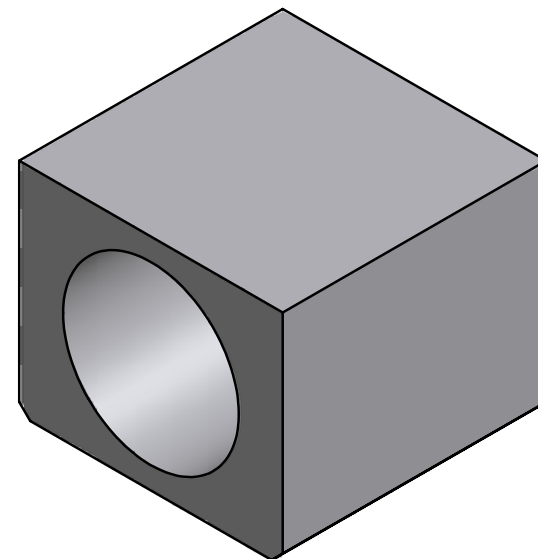

4

3

2

1

TOLERANCES UNLESS OTHERWISE NOTED: FRACTIONAL: 0"-6": ±1/64" 6"-24": ±1/32" 24": ±1/16" DECIMAL: X.X: ±0.1000" X.XX: ±0.0100" X.XXX: ±0.0050" X.XXXX: ±0.0001" ANGLES: ±0.5° FINISH: 125 MICRO INCHES BREAK ALL SHARP EDGES & CORNERS 1/64" MAX			DRAWN: vernon CHECKED: vernon DESIGNED: vernon ENGINEER: vernon	9/8/2004 	Cassegrain ADC TITLE: SHAFT MOUNT	PROJECT CODE: A8010 NEXT ASSY:	DWG NO: A8012	QTY: 2	NET A 1/1
MATERIAL: STEEL FINISH:	QTY: 2		PROJECT CODE: A8010 NEXT ASSY:	DWG NO: A8012	NET A 1/1				