

REV	DRWN	CHK'D	DATE	DESCRIPTION
B	VRW	VRW	12/8/04	INCREASE THICKNESS
C	VRW	VRW	12/9/04	ADD PILOT

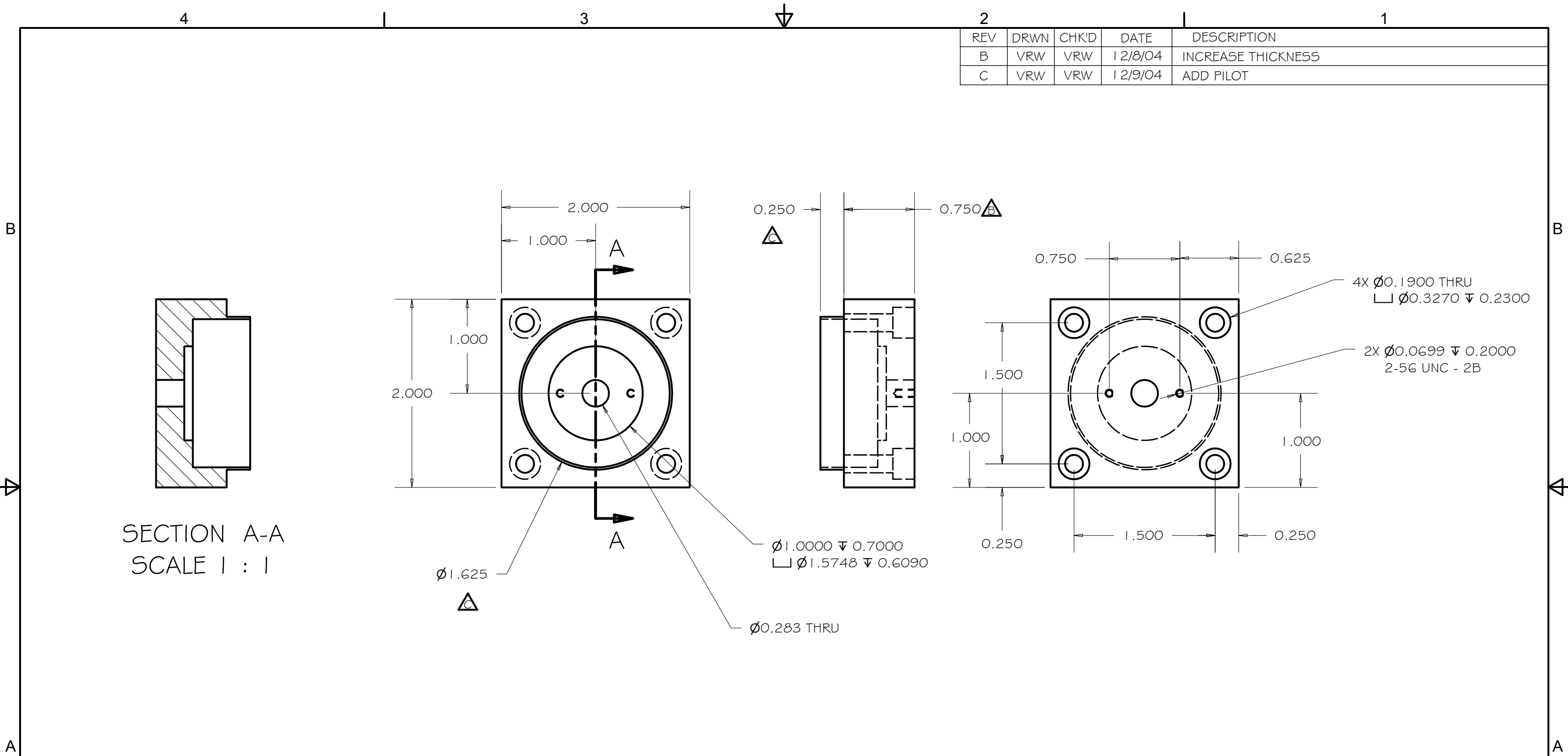

TOLERANCES UNLESS OTHERWISE NOTED:
 FRACTIONAL: 0"-6": $\pm 1/64$ " 6"-24": $\pm 1/32$ "
 24"+: $\pm 1/16$ "
 DECIMAL: X.X: ± 0.1000 " X.XX: ± 0.0100 "
 X.XXX: ± 0.0050 " X.XXXX: ± 0.0001 "
 ANGLES: $\pm 0.5^\circ$ FINISH: 125 MICRO INCHES
 BREAK ALL SHARP EDGES & CORNERS 1/64" MAX

MATERIAL: STEEL FINISH: 2

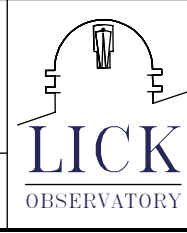

DRAWN	vernon	9/4/2003
CHECKED		
DESIGNED	vernon	
ENGINEER	vernon	
QTY: 1		

PROJECT CODE		DWG NO	REV
NEXT ASSY		A1215	C
A1000			1

Cassegrain ADC

BALL SCREW CAP, FWD