

| REV | DRWN | CHK'D | DATE | DESCRIPTION |
|-----|------|-------|--------|-------------------------------------|
| B | VRW | VRW | 9/8/04 | REVISE A1528 FOR EASIER FABRICATION |

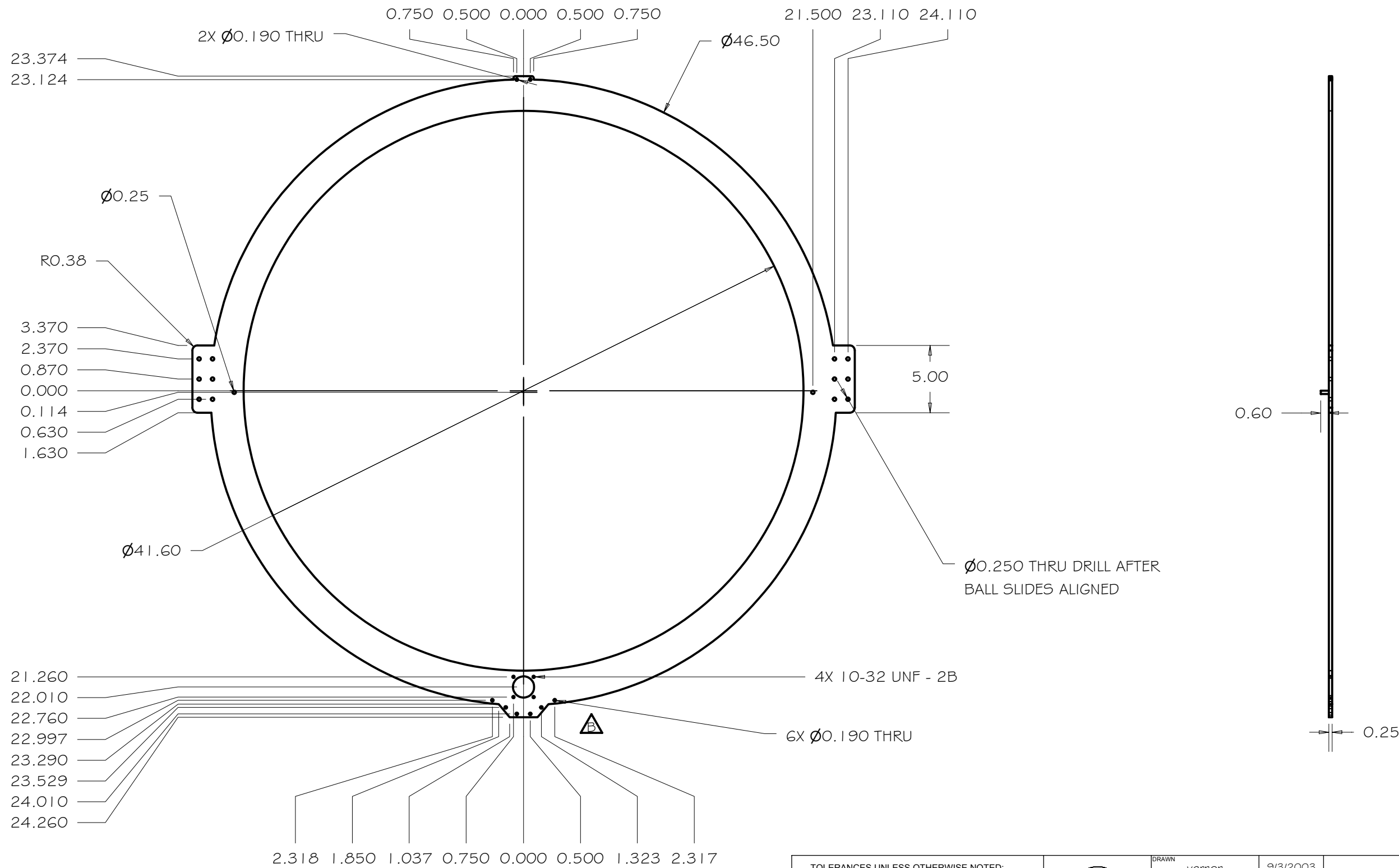

TOLERANCES UNLESS OTHERWISE NOTED:
 FRACTIONAL: 0"-6": ±1/64" 6"-24": ±1/32"
 24"+: ±1/16"
 DECIMAL: X.X: ±0.1000" X.XX: ±0.0100"
 X.XXX: ±0.0050" X.XXXX: ±0.0001"
 ANGLES: ±0.5° FINISH: 125 MICRO INCHES
 BREAK ALL SHARP EDGES & CORNERS 1/64" MAX

| | |
|----------|--------|
| MATERIAL | FINISH |
| STEEL | 2 |

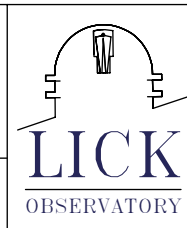

| | | |
|----------|--------|----------|
| DRAWN | vernon | 9/3/2003 |
| CHECKED | | |
| DESIGNED | vernon | |
| ENGINEER | vernon | |
| QTY: 1 | | |

| | |
|----------------|--------|
| Cassegrain ADC | |
| TITLE | |
| RING, FWD | |
| PROJECT CODE | DWG NO |
| AI100 | A1172 |
| NEXT ASSY | REV |
| | B |