

4

3

2

1

REV	DRWN	CHK'D	DATE	DESCRIPTION

B

B

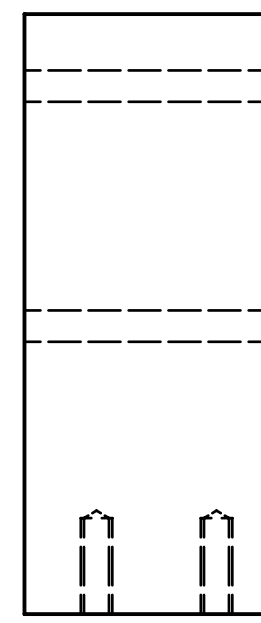
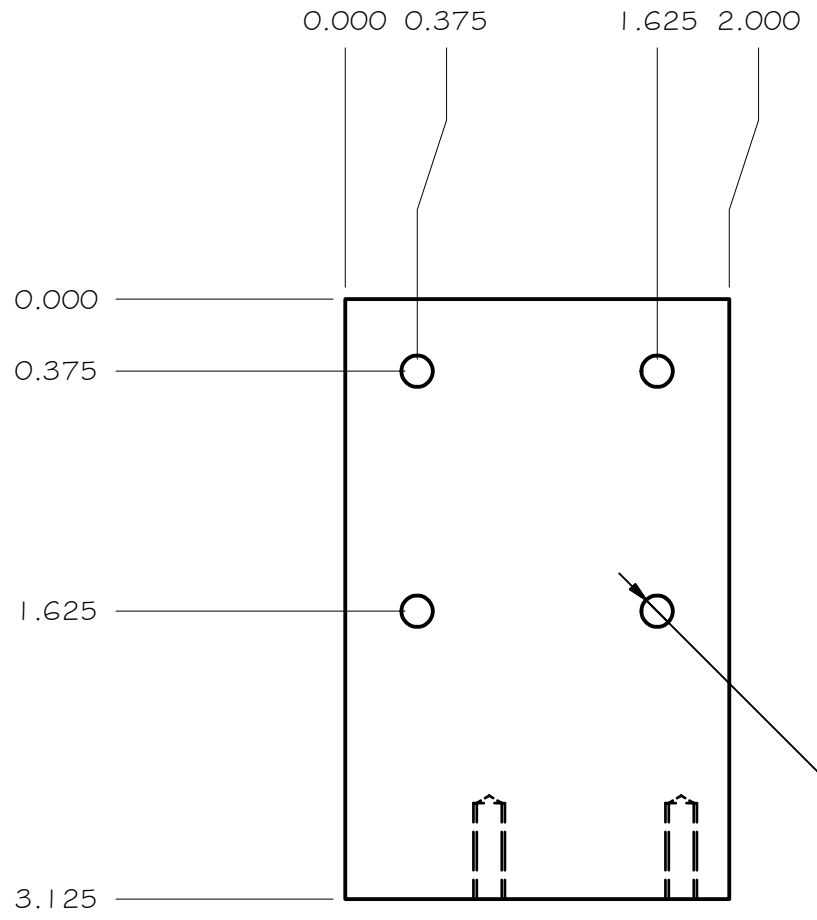

A

A

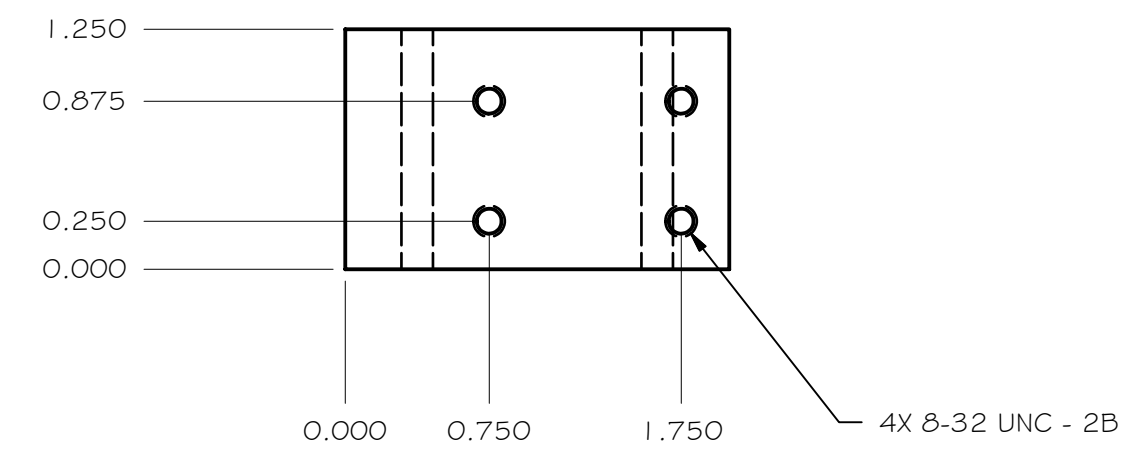

SCALE 1 : 1

TOLERANCES UNLESS OTHERWISE NOTED:
 FRACTIONAL: 0"-6": ±1/64" 6"-24": ±1/32"
 24"+: ±1/16"
 DECIMAL: X.X: ±0.1000" X.XX: ±0.0100"
 X.XXX: ±0.0050" X.XXXX: ±0.0001"
 ANGLES: ±0.5° FINISH: 125 MICRO INCHES
 BREAK ALL SHARP EDGES & CORNERS 1/64" MAX

MATERIAL	FINISH
ALUMINUM	

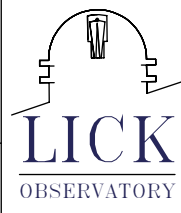

DRAWN	vernon	5/10/2005
CHECKED		
DESIGNED	vernon	
ENGINEER	vernon	

Cassegrain ADC

TITLE
SPACER BLOCK, THICK, RIGHT

QTY: 1

PROJECT CODE	DWG NO	REV
	A112	A
NEXT ASSY		1
A100		1

4

3

2

1

A

A