

2	1	1	1	1
REV	DRWN	CHK'D	DATE	DESCRIPTION

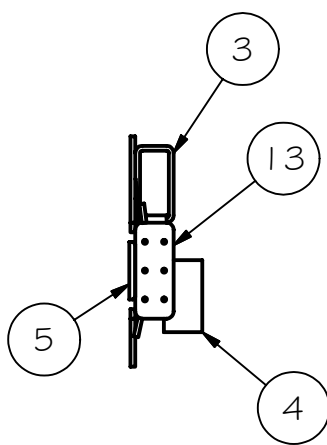
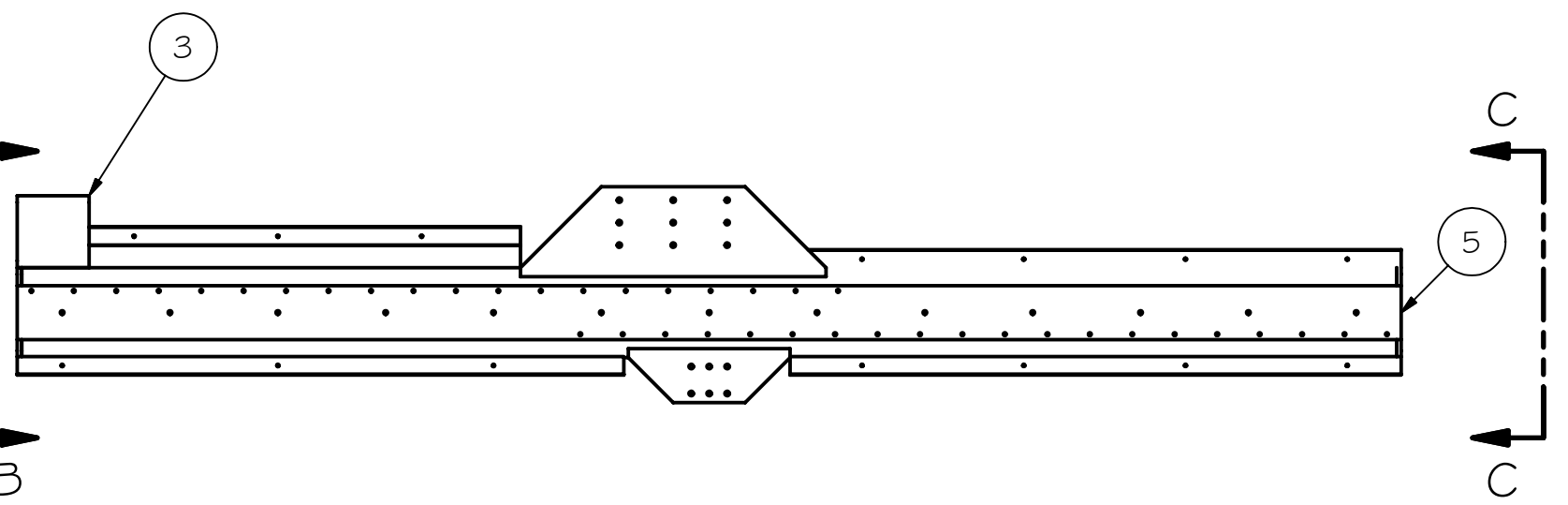
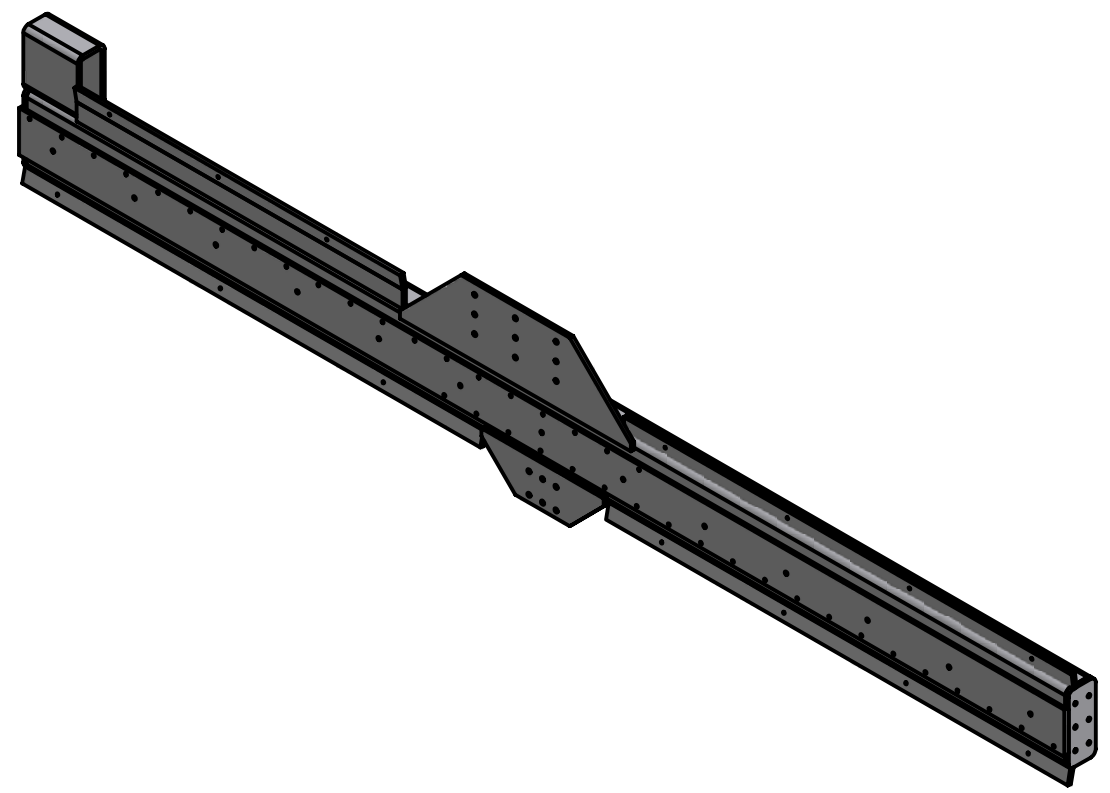
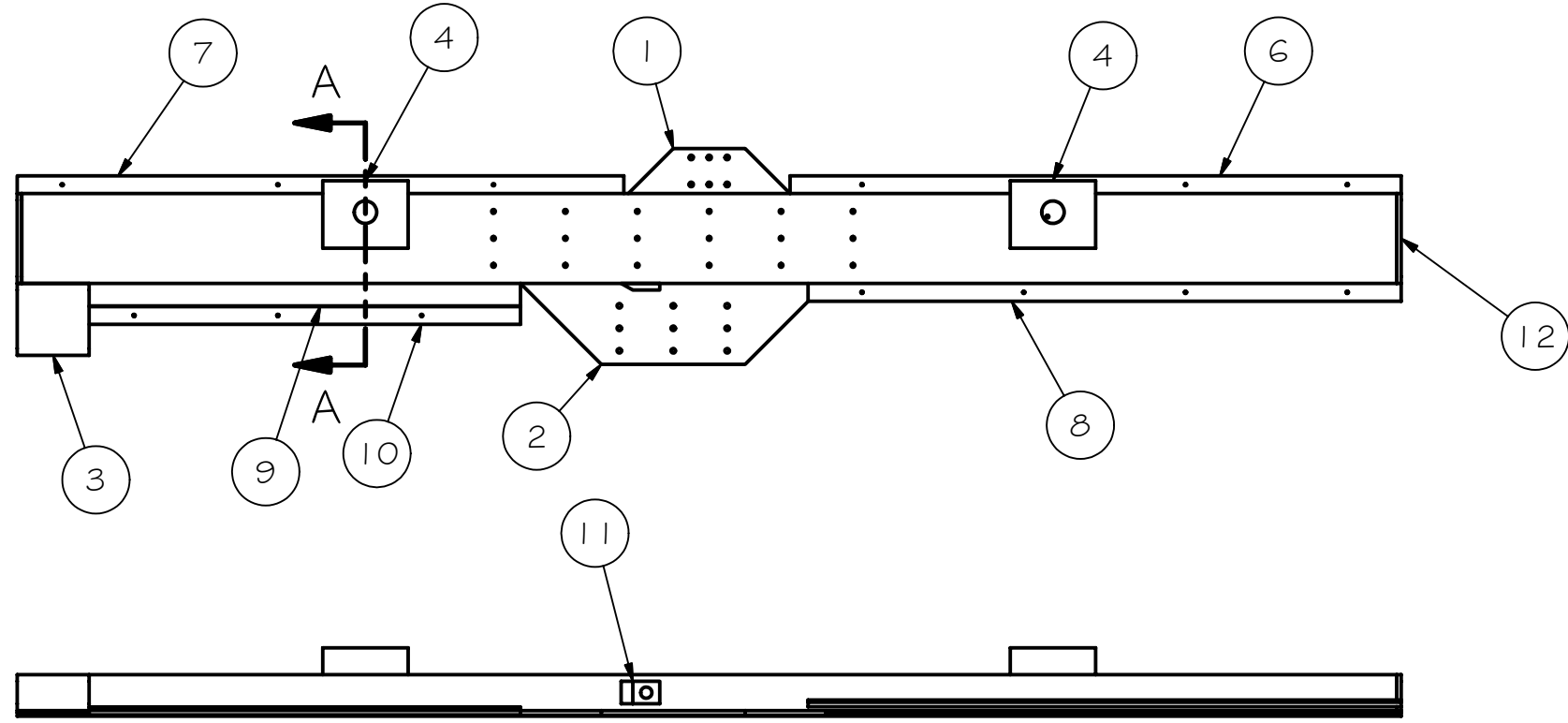

Parts List			
ITEM	QTY	PART NUMBER	DESCRIPTION
1	1	A1112	GUSSETT, UPPER
2	1	A1113	GUSSETT, LOWER
3	1	A1114	PICKUP TUBE
4	2	A1115	ROLLER MOUNT
5	1	A1116	RAIL BASE
6	1	A1117	CLADDING STRIP 1
7	1	A1118	CLADDING STRIP 2
8	1	A1119	CLADDING STRIP 3
9	1	A1120	CLADDING STRIP 4
10	1	A1121	CLADDING STRIP 5
11	1	A1122	PICKUP HOLE
12	2	A1123	TUBE END CAP
13	1	A1131	SUPPORT TUBE, RIGHT

- NOTES:
 1) COMPLETE ALL WELDS
 2) STRESS RELIEVE
 3) BLANCHARD GRIND SURFACE OF ITEM 5
 4) MACHINE HOLES

TOLERANCES UNLESS OTHERWISE NOTED:
 FRACTIONAL: 0"-6": ±1/64" 6"-24": ±1/32"
 24"+: ±1/16"
 DECIMAL: X.X: ±0.1000" X.XX: ±0.0100"
 X.XXX: ±0.0050" X.XXXX: ±0.0001"
 ANGLES: ±0.5° FINISH: 125 MICRO INCHES
 BREAK ALL SHARP EDGES & CORNERS 1/64" MAX

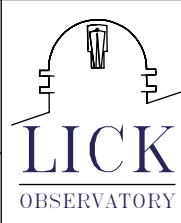

DRAWN: vernon 8/14/2003
 CHECKED: _____
 DESIGNED: vernon
 ENGINEER: _____

Cassegrain ADC
 TITLE: SUPPORT WELDMENT, RIGHT
 PROJECT CODE: _____ DWG NO: A1130
 NEXT ASSY: A1100
 REV: A 1/4